



# PONYBENCH-PR 35 PONYBENCH-PR PLUS 35

---

INSTALLAZIONE USO E MANUTENZIONE

Istruzioni originali

OPERATING AND SERVICE MANUAL

Translation of the original instructions

MANUEL D'UTILISATION ET DE MAINTENANCE

Translation of the original instructions

BEDIENUNGS - UND WARTUNGSHANDBUCH

Translation of the original instructions

MANUAL DE INSTRUCCIONES DE USO Y MANUTENCIÓN

Translation of the original instructions

Carefully read the instructions in this manual before using PONYBENCH

## THE COMPANY



RESERVES OWNERSHIP OF THIS MANUAL, FORBIDS REPRODUCTION OR COMMUNICATION THEREOF TO THIRD PARTIES WITHOUT THE AUTHORISATION OF THE OWNER AND RESERVES THE POWER TO SAFEGUARD ITS RIGHTS BY PROSECUTING ALL TRANSGRESSORS IN ACCORDANCE WITH THE LAW.

This manual forms an integral part of the PONYBENCH lift and must be kept carefully for consultation whenever required.

Further copies are available upon request from:



**Spanesi S.p.A.**

Via Praarie 56/II, Loc. Cavino  
35010 S.G. delle Pertiche (PD)

**Servizio Assistenza Tecnica**

tel.: (0039)049 9333211

Fax: (0039) 049 5741295

e-mail: [spanesi@spanesi.it](mailto:spanesi@spanesi.it)

web: [www.spanesi.com](http://www.spanesi.com)

# CONTENT

<b>1.</b>	<b>DESCRIPTION AND MAIN FEATURES .....</b>	<b>43</b>
1.1.	INTRODUCTION .....	43
1.2.	GUARANTEE .....	43
1.2.1.	ITEMS EXCLUDED FROM THE GUARANTEE .....	43
1.3.	CE CERTIFICATION .....	44
1.4.	INTENDED USE .....	44
1.5.	IDENTIFICATION .....	44
1.6.	DESCRIPTION OF THE LIFT .....	45
1.7.	NOISE LEVEL .....	47
1.8.	TECHNICAL SPECIFICATIONS .....	47
<b>2.</b>	<b>SAFETY AND ACCIDENT PREVENTION REGULATIONS .....</b>	<b>48</b>
2.1.	HAZARD LEVELS .....	48
2.2.	TERMINOLOGY .....	48
2.3.	SAFETY SIGNS .....	49
2.4.	CLOTHING .....	49
2.5.	ECOLOGY AND POLLUTION .....	49
2.6.	SCRAPPING, PLACING THE EQUIPMENT OUT OF USE .....	50
2.7.	SAFE USE .....	50
2.8.	SAFE MAINTENANCE .....	51
<b>3.</b>	<b>TRANSPORT, UNLOADING AND COMMISSIONING .....</b>	<b>52</b>
3.1.	TRANSPORT AND UNLOADING .....	52
3.2.	UNPACKING .....	52
3.3.	INSTALLATION .....	52
3.3.1.	CHOOSING THE POSITION .....	52
3.3.2.	PREPARING THE PIT (PONYBENCH PR PLUS 35).....	53
3.3.3.	CONTROL OPERATIONS TO BE PERFORMED BEFORE INSTALLATION .....	53
3.3.4.	LIFT INSTALLATION .....	54
3.4.	CONNECTIONS .....	55
3.4.1.	CONNECTING THE HYDRAULIC SYSTEM .....	55
3.4.2.	CONNECTING THE PNEUMATIC SYSTEM .....	56
3.4.3.	CONNECTING THE ELECTRICAL SYSTEM .....	56
3.4.3.1.	CONNECTING THE ELECTRICAL SYSTEM .....	56
3.4.3.2.	CHECK MOTOR POLARITY .....	57
3.5.	AFTER CONNECTION .....	58
<b>4.</b>	<b>USE INSTRUCTIONS .....</b>	<b>59</b>
4.1.	BEFORE USE .....	59
4.2.	CHECKING OPERATION OF SAFETY DEVICES .....	59
4.2.1.	EMERGENCY BUTTON .....	59
4.2.2.	RESET BUTTON .....	59
4.2.3.	CHECKING OPERATION OF THE FALL-PROOF SAFETY HOOK .....	60

4.3. USE OF THE LIFT .....	60
4.3.1. RAISING THE PONYBENCH LIFT .....	60
4.3.2. LOWERING THE PONYBENCH LIFT .....	62
5. SAFETY DEVICES .....	63
5.1. SAFETY DEVICES PONYBENCH .....	63
5.2. NON-RETURN MECHANICAL SAFETY DEVICE.....	63
5.3. EMERGENCY STOP BUTTON .....	63
5.4. SAFETY LOCK VALVE .....	63
5.5. RESET BUTTON .....	63
5.6. LOW VOLTAGE CONTROLS ELECTRICAL CIRCUIT .....	63
5.7. MAGNETO-THERMAL OVERLOAD CUTOUT .....	63
5.8. SAFETY WARNING SIGNS .....	63
5.9. DEVICE TO STOP WHEELS.....	63
6. LIFT ACCESSORIES .....	64
6.1. STANDARD ACCESSORIES .....	64
6.1.1. PONYBENCH STANDARD ACCESSORIES.....	64
7. SYSTEMS .....	65
7.1. PONYBENCH PR PLUS LIFT HYDRAULIC DIAGRAM .....	65
7.2. WIRING DIAGRAM.....	66
8. MAINTENANCE .....	68
8.1. ROUTINE MAINTENANCE .....	68
8.1.1. ONCE A DAY:.....	68
8.1.2. WEEKLY:.....	68
8.1.3. ONCE A MONTH .....	68
8.1.4. ONCE EVERY TWO YEARS:.....	68
8.2. EXTRAORDINARY MAINTENANCE .....	68
8.3. PLACING THE EQUIPMENT OUT OF USE.....	69
8.4. SCRAPPING.....	69
9. TROUBLESHOOTING .....	70
9.1. FAULTS, CAUSES AND SOLUTIONS .....	70
10. SPARE PARTS .....	71
10.1. DRAWING 1: PONYBENCH LIFT EXPLODED DRAWING .....	72
10.2. EXPLODED VIEW OF PONYBENCH LIFT .....	75

# 1. DESCRIPTION AND MAIN FEATURES

## 1.1. INTRODUCTION

This manual provides instructions for installation and all information considered necessary for knowledge, correct use and routine maintenance of the PONYBENCH-PR 35 and PONYBENCH-PR PLUS 35 SCISSOR LIFT, manufactured by SPANESI S.p.A., San Giorgio delle Pertiche (Padova) - Italy.

For the sake of simplicity from now on in this manual the lift will be called PONYBENCH.

The following does not provide a complete description of the various lift parts or a detailed explanation of their operation.

The user will, however, find everything he needs to know for safe use and maintenance of the lift.

- PONYBENCH-PR 35 is an electro-hydraulic over floor lift.
- PONYBENCH-PR 35 is an electro-hydraulic infloor lift

SPANESI S.p.A. has produced this handbook on using PONYBENCH.

This manual is an integral part of the product and must be kept carefully and in good condition for consultation throughout the life of PONYBENCH.

Further copies of the instruction manual can be obtained on request from:



**Spanesi S.p.A.**

Via Praarie 56/II, Loc. Cavino  
35010 S.G. delle Pertiche (PD)

**Servizio Assistenza Tecnica**

tel.: (0039)049 9333211

Fax: (0039) 049 5741295

e-mail: [spanesi@spanesi.it](mailto:spanesi@spanesi.it)

web: [www.spanesi.com](http://www.spanesi.com)

The instructions given in this manual must be followed to ensure operator safety, correct operation, economic running and long life of the machine. It is of fundamental importance to observe all the directions given in this manual.



**WARNING! SPANESI S.p.A. declines all responsibility for direct or indirect damage caused to people, animals, or property, due to negligence or failure to comply with these instructions.**

## 1.2. GUARANTEE

SPANESI S.p.A. guarantees the PONYBENCH lift and its accessories for 12 months from the date of purchase. This guarantee covers repair or replacement free of charge of parts which, after careful examination by the manufacturer's Technical Department, are found to be defective, excluding all electrical parts.

The guarantee is limited to defects in material and ceases if the parts returned are found to have been tampered with or dismantled by non-authorized personnel. Responsibility for direct and indirect damage to persons, animals or property due to failure or faulty operation of the machine are excluded from the guarantee.

Expenses relating to replacement of the lubricants, transport expenses, any customs duties, VAT and any other expenses not stated in writing in the supply contract must in any case be borne by the purchaser.

Replacements or repairs of materials under guarantee do not extend the guarantee terms. The purchaser can exercise the rights offered by the guarantee only if he has observed the terms of the guarantee provided in the supply contract. Whenever the parties do not wish to submit to an arbitration judgement, any disputes arising from the supply contract and any other case in which a legal decision is required will be referred exclusively to the Court of Padova.

### 1.2.1. ITEMS EXCLUDED FROM THE GUARANTEE

Upon delivery, the purchaser must check that the product has not been damaged during shipment and that all the accessories have been included and are in perfect condition.

Any claims must be notified within 8 days of delivery of the lift. In addition to the cases provided for in the supply contract, the guarantee will be considered null and void:

- If the machine has been used incorrectly by the operator.
- If the damage is due to insufficient maintenance.
- If the lift is overloaded, exceeding the maximum capacity.
- If the lift has been altered and the damage is caused by these alterations as a result of repair work carried out by the user without the consent of SPANESI S.p.A. or due to the use of non-original spare parts.
- If the instructions given in this manual are not followed.

### 1.3. CE CERTIFICATION

The EC Directive 2006/42 more commonly known as the “Machines Directive”, lays down the conditions under which the machine can be put on the market. This Directive prescribes that all machine can be sold and used only if they do not endanger the safety and health of people, pets or property.

PONYBENCH is, therefore, delivered to the customer, complete with:

- **EC declaration of conformity**
- **CE mark**
- **Instruction Manual**

### 1.4. INTENDED USE

The PONYBENCH is a machine designed and built exclusively for lifting vehicles to the height required-It is therefore also suitable for the lifting of vehicles to the height required to facilitate sanding and/or other work.

- PONYBENCH must be used exclusively for lifting vehicles observing the capacity limits indicated on the identification plate.
- The vehicle to be lifted must be positioned on the PONYBENCH lift with its weight distributed as evenly as possible.
- PONYBENCH must not be used for washing or degreasing vehicles.
- PONYBENCH is not suitable for lifting people.
- PONYBENCH can be used with pull systems.



**WARNING! The use of the PONYBENCH lift for work operations or purposes other than those specified in this manual is considered inappropriate and therefore absolutely forbidden. SPANESI S.p.A. declines all responsibility for damage to persons, animals or property due the inappropriate use of the PONYBENCH lift or the failure to comply with these instructions.**

### 1.5. IDENTIFICATION

The manufacturer’s Identification plate (Figure 1a-1b), is fitted on the structure of PONYBENCH, and shows the following data:

- (A) Name and address of the manufacturer
- (B) Lift Model/Type
- (C) Max. hydraulic circuit pressure in Bar
- (D) Lift serial number
- (E) Max. capacity in kg
- (F) Operating voltage in Volts (\*)
- (G) Operating frequency in Hertz (\*)
- (H) Year of manufacture
- (I) CE mark

The information given in the identification plate must always be quoted in any requests for technical support and/or supply of spare parts.

<b>SPANESI</b> S.p.A.		Made in Italy	
Via Praarie 56/II - S. Giorgio d. Pertiche (PD) - ITALY Tel. +39 049 9333211 - Fax +39 049 9333210			
<b>MOD.</b> <i>type</i>	Ponybench PR 35	<b>PRESS. MAX.</b> <i>max. pressure</i>	<b>310 bar</b>
<b>N° MATR.</b> <i>serial n.</i>		<b>PORTATA MAX.</b> <i>max. load</i>	<b>3500 kg</b>
<b>VOLT</b>	<b>230 V 3 Ph</b>	<b>HERTZ</b>	<b>50 Hz</b>
<b>ANNO</b> <i>year</i>	<b>2022</b>	<b>MASSA</b> <i>weight</i>	<b>675 kg</b>

Figure 1a

<b>SPANESI</b> S.p.A.		Made in Italy	
Via Praarie 56/II - S. Giorgio d. Pertiche (PD) - ITALY Tel. +39 049 9333211 - Fax +39 049 9333210			
<b>MOD.</b> <i>type</i>	Ponybench PR PLUS 35	<b>PRESS. MAX.</b> <i>max. pressure</i>	<b>310 bar</b>
<b>N° MATR.</b> <i>serial n.</i>		<b>PORTATA MAX.</b> <i>max. load</i>	<b>3500 kg</b>
<b>VOLT</b>	<b>230 V 3 Ph</b>	<b>HERTZ</b>	<b>50 Hz</b>
<b>ANNO</b> <i>year</i>	<b>2022</b>	<b>MASSA</b> <i>weight</i>	<b>675 kg</b>

Figure 1b

## 1.6. DESCRIPTION OF THE LIFT

The PONYBENCH lift is a machine designed and built for lifting vehicles to the height required to facilitate the inspection and/or sanding of motorvehicle bodies.

- The PONYBENCH consists basically of a mobile welded steel frame raised by means of a single-acting hydraulic jack which controls a mechanism consisting of two pairs of connecting rods that form the arms of the pantograph mechanism. The power is supplied by a hydraulic unit that sends the pressurised oil to the lifting jack through a gear pump.

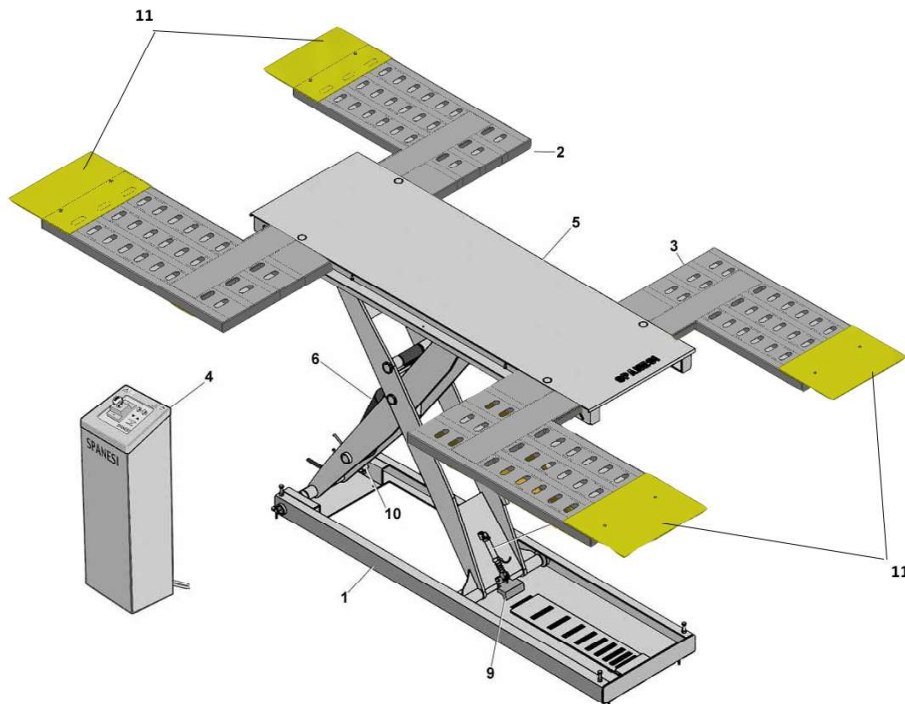

Figure 2a : PERSPECTIVE VIEW OF THE PONYBENCH-PR PLUS

The essential parts of the lifts are (fig. 2a/2b):

- 1) Fixed base frame structure sunken into the floor;
- 2) wheel support platform
- 3) wheel support platform
- 4) Control console
- 5) Upper movable platform;
- 6) Single-acting hydraulic jack;
- 7) Pantograph lifting arms;
- 8) Anti-fall safety hook control pneumatic cylinder
- 9) Anti-fall safety hook;
- 10) Stroke-end microswitch;
- 11) Device to stop Wheel;

The PONYBENCH is used as a lift in bodyshops and is not equipped for use with a pull system. The base frame structure (1) to which all the stress is transferred composed of a welded steel structure sunken or above the floor to which the supports and runners for the sliding wheels of the pantograph lifting arms and the safety stops that engage the in fall-proof safety hook (9) are fitted. The upper movable platform (5) for the lifting of the vehicle is composed of a welded steel structure equipped to receive the platform (2) that support the vehicle wheels.

The lifting system consists of a single-acting hydraulic jack (6) driven by the gear pump.

The jack operates a pair of lifting arms (7) that controls the movement of the lifting platform.

The lift is moved up and down by means of a gear pump driven by an electrohydraulic unit installed in the control console (4). The pump pressurises a hydraulic circuit that permits in and out movement of the rod in the lifting jack. The hydraulic circuit is provided with a pressure relief valve and a safety lock valve to protect against the breakage of the flexible pipes.

The electric cables that connect the lift to the control console and the flexible pipes that deliver the control unit oil and the compressed air are housed from in a protective underground sheath (not provided). The stability of position of the lift's upper movable platform is guaranteed by a safety system consisting of a safety hook (9) automatically controlled by a pneumatic cylinder (8) that engages a series of steel blocks welded onto the base sheet as the lift descends.

A stroke-end microswitch (10) obliges the operator to perform descent in two sections, the first to a maximum height of approx. 30-35 cm from the floor, the second all the way until the movable platform has completely lowered.

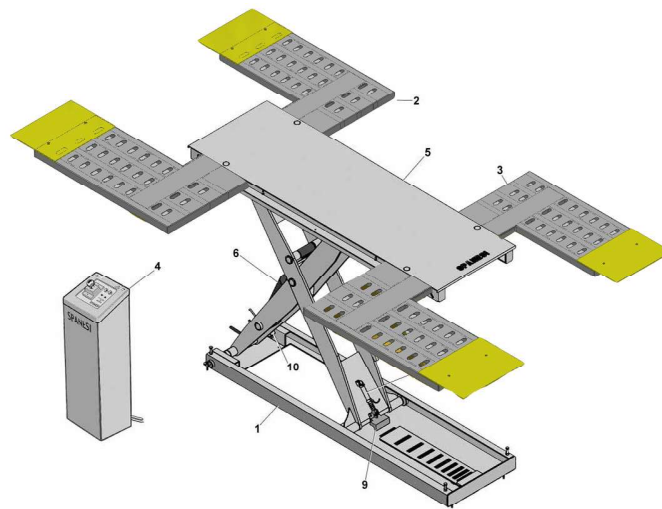

Figure 2a : PERSPECTIVE VIEW OF THE PONYBENCH-PR PLUS

## 1.7. NOISE LEVEL

PONYBENCH's noise level was measured with the control pumps operating, load-free under normal operating conditions. Measurements were taken to conform to EN ISO 3746/2011 standard by a competent laboratory using a precision integrating phonometer. The test results are indicated below:

		PONYBENCH-PR 35 & PR PLUS 35
Average sound pressure level LpAm	dB(A)	68.1
Sound pressure at operator's post LpA	dB(A)	71.9
Sound power level LwA	dB(A)	85.5

## 1.8. TECHNICAL SPECIFICATIONS

The essential technical data are provided in the table. For more-detailed information on the product's technical features, contact the Manufacturer directly.

SPECIFICATION	MEASURE	PONYBENCH-PR 35 & PR PLUS 35
Max. capacity of lift	Kg	3.500
Max. height (base - platform)	mm	1420
Length of upper mobile platform	mm	2210
Width of upper mobile platform	mm	700
Length of base frame	mm	2185.5
Width of base frame	mm	600
Operating pressure of lift hydraulic circuit	bar	310
Operating pressure of pneumatic supply circuit	bar	8
Weight of lift	Kg	560
Ascent time	s	61
Descent time	s	65
Three-phase power supply version	V	400 a.c.
Single-phase power supply version	V	230 a.c.
Power supply frequency	Hz	50
Three-phase electric motor power	KW	1.5
Auxiliary circuit voltage with 400 V three-phase power supply	V	24 a.c.
Auxiliary circuit voltage with 230 V single-phase power supply	V	230 a.c.
Control unit weight	Kg	50

## 2. SAFETY AND ACCIDENT PREVENTION REGULATIONS

### 2.1. HAZARD LEVELS

Operator and personnel safety is the main concern of machine designers and manufacturers. When designing a new machine, the designer tries to take account of all possible hazards and risks connected with the use of the machine, taking all suitable precautions to make the equipment as safe as possible. The number of accidents nevertheless remains very high due above all to careless and clumsy operator use. You are therefore advised to read this manual very carefully and in particular this section concerning safety precautions, and make sure that you always use the machine correctly and follow the instructions in this manual.



**WARNING!** Read the following instructions carefully. Anyone who fails to observe them may suffer permanent injury or permanently injure other persons or animals or damage property. SPANESI declines all responsibility for direct or indirect damages caused by failure to observe the safety precautions and accident prevention directions set out below.

Pay attention to the hazard warning sign when it appears in this manual and observe all safety provisions.

There are three types of hazard warning sign:



#### **DANGER**

This sign warns that if the operations described are not correctly performed, they will cause serious injury or death or involve long term health risks. The DANGER sign indicates the highest risk level.



#### **WARNING!**

This sign warns that if the operations described are not correctly performed, they can cause serious injury or death or involve long term health risks. The WARNING sign indicates a risk level that is lower than that of the DANGER sign.



#### **CAUTION!**

This sign warns that if the operations described are not correctly performed, the machine can be damaged. The CAUTION sign indicates a lower level of risk than those above.



**WARNING!** SPANESI S.p.A. declines all responsibility for direct and indirect damage caused by incorrect use of the PONYBENCH lift and/or caused by modifications carried out without the manufacturer's authorisation.

### 2.2. TERMINOLOGY

The hazard levels refer to specific situations that may occur during use and can directly involve the machine, operator and exposed persons. The following list gives the meanings of the terms used in this manual to indicate situations and/or operations that involve hazards:

- **DANGEROUS AREA:** any area inside and/or near a machine within which the presence of a person is a risk to the safety and health of the said person (Art. 1.1.1., sub-paragraph 1, annex I of Directive 2006/42/EC).
- **EXPOSED PERSON:** anyone who is entirely or partly within a dangerous area (Art. 1.1.1, sub-paragraph 2, annex I of Directive 2006/42/EC).
- **OPERATOR:** the person or persons charged to install, operate, adjust, maintain, clean, repair and transport a machine (Art. 1.1.1, sub-paragraph 3, annex I of Directive 2006/42/EC).
- **USER:** the person, body or company who/which has purchased or leased/hired the lift to use it for the purposes intended by the manufacturer.
- **SPECIALISED PERSONNEL:** any person specifically trained and authorised to carry out maintenance operations requiring special knowledge of the lift, its operation, of the safety devices and of the maintenance methods. These specialised personnel must be able to recognise the dangers present on the lift, thus avoiding hazardous situations.
- **AUTHORISED WORKSHOPS FOR TECHNICAL SUPPORT:** any structure provided with specialised personnel and duly authorised by SPANESI S.p.A. to provide all the technical support and perform the maintenance operations necessary to keep the lift constantly in perfect working order.

### 2.3. SAFETY SIGNS

The safety signs described in this manual are affixed to the product in appropriate positions and indicate which operations should be carried out as well as unsafe or hazardous situations. The labels must be kept clean and immediately replaced when they come off, are damaged or illegible. Carefully read and learn the meaning of the safety signs:



The instruction manual must be carefully read before using the machine.



Before carrying out any maintenance operation on the machine, the machine must be stopped, disconnected from its energy sources and the instructions manual must be carefully consulted.



Danger of crushing legs: keep at a safe distance during raising and lowering of the lift;



Danger of falling: never climb onto the lift or be lifted by it.



Stop: do not withdraw the pad supports from the adhesive surface for resting the vehicles, beyond the indicated reference mark;

### 2.4. CLOTHING

Use clothing suitable for the machine and the work place:

- Do not wear loose-fitting clothes: they can get caught in the moving parts of the lift.
- Do not wear moccasins, clogs, slippers or other types of footwear which could hinder your mobility and balance.
- If specified in the regulations in force in the country in which the machine is being used, the operator must wear suitable safety clothing such as: helmet, goggles, gloves, appropriate footwear, etc.

### 2.5. ECOLOGY AND POLLUTION

The following are the minimum prescriptions to be observed in order to minimise the risks of environmental impact through use of the lift:

- PONYBENCH is not suitable for washing and/or degreasing vehicles: the products used could damage the lift and cause pollution.
- If the regulations of the country in which the machine is being used specify noise emission limits, suitable protective aids should be provided for compliance with the standards (ear plugs, headphones, etc.).
- Observe the laws of the country in which the lift is being used, concerning use and disposal of products used for cleaning and maintenance of the PONYBENCH, in accordance with the manufacturer's recommendations.
- When replacing worn-out parts or dismantling the machine, observe the anti-pollution laws of the country in which the lift is being used.

## 2.6. SCRAPPING, PLACING THE EQUIPMENT OUT OF USE

Whenever the equipment must be scrapped or placed out of use for a long period of time, the following precautions must be taken to avoid polluting the environment:

- All the hydraulic oil in the electro-hydraulic unit, jacks and pipes must be carefully drained.
- The other parts of the lift must be treated in the same way as special waste and the machine must be dismantled by separating its components into separate groups in observance of the anti-pollution laws in force in the nation of use.

Bear in mind that:

- Spent oil is considered special waste.
- All rubber parts are considered special waste.
- All scrap metal is considered special waste.

## 2.7. SAFE USE

PONYBENCH consists essentially of two units: the lift, and the control panel. We advise you to read the safety prescriptions below.



**WARNING! SPANESI S.p.A. declines all responsibility for damage caused by failure to observe the safety and accident prevention regulations described below.**

When using the lift, you must observe the following prescriptions:

- The lift must never be operated by anyone who has not completely read, understood and assimilated the contents of this instruction manual.
- The lift must never be operated by inadequately trained or inexperienced personnel or personnel not in good health.
- Do not exceed the carrying capacity indicated on the identification plate: the overloading of the machine creates the serious risk of breakages and invalidates the guarantee.
- Never touch, lean on, or stand between moving parts during raising and lowering of the vehicle lift.
- Never lift persons, animals or things. The lift has been designed exclusively for the lifting of vehicles within the load limits indicated on the identification plate.
- Never lift the vehicle with persons or unstable objects on board, which could fall causing damage or injury.
- Never use ladders, stools or other objects to rest on during the operations: the operator must always stand firmly on the floor.
- Never walk on the upper mobile platform even when the lift is fully lowered.
- Always position the vehicle on the lift in such way that the weight is a evenly distributed and centred as possible. The doors of the vehicle must be closed. Nothing must protrude beyond the vehicle. The centre of gravity of the vehicle must be positioned as near as possible to the centre of the lift
- The vehicle parts must always be dismantled and/or reassembled with the lift positioned at the level of the first safety stop.
- Before using the lift, always check that all safety devices and the lift structure are in perfect working order.
- Before operating the vehicle lift, make sure that there are no people underneath it or within a range of less than one metre around it.
- The vehicle must be driven onto the lift or manoeuvred by authorised personnel only, as specified in the Highway Code in force in the country in which the lift is being used.
- Always activate the parking brake.  
No objects must protrude beyond the profile of the vehicle.
- It is compulsory, before performing a descent, to make sure that there are no objects beneath or around the vehicle. Any such objects must be removed.
- Before lowering the lift, always make sure that there are no pipes, hoses, or power tool cables in the area that may be crushed.
- Always check that the base of the lift where the safety hook engages is always free of all obstructions.
- The lift must be installed by qualified personnel only, fully observing all the instructions in this manual.
- PONYBENCH must be put in a place protected against water and ice: The machine was designed and built to operate indoors only. The appliance must be used only indoors in places free from explosion and fire hazards.
- The floor bearing PONYBENCH must be flat, smooth and horizontal.
- The area above the PONYBENCH must not be occupied by electrical equipment connected to the mains, in order to prevent electrical discharges created by the collision or contact of the vehicle with the said equipment.
- The control console must be positioned at a safe distance from the hydraulic unit as indicated in this Manual in a position that provides a full view of the work area.
- In the event of danger, promptly press the emergency stop button on the control console.
- Before beginning work, the operator should be familiar with the controls.
- When the lift is being raised, make sure the vehicle does not collide with the workshop ceiling.
- In order to access the underside of the vehicle, the operator must raise the lift high enough to work while standing.

- In the event of skin contact with the lift mechanism oil, wash the affected area with plenty of soap and water.
- In the event of faulty operation, always contact the Manufacturer to avoid inappropriate action.
- Only accessories specifically supplied by the manufacturer may be used.

## 2.8. SAFE MAINTENANCE

To ensure safety when maintaining PONYBENCH, the following instructions must be observed:

- Removal or tampering the safety devices is prohibited.
- Welding torch or machine cutting or drilling of holes into the lift structure is prohibited.
- Never operate the lift even when only one safety sign is missing from the place where it was affixed by the manufacturer.
- The safety or danger signs and the capacity table fitted on the lift provide basic accident-prevention instructions. These signs and the table must always be kept clean and replaced immediately when they come off, even partially, or are damaged.
- Always disconnect the electrical and/or pneumatic power supply before carrying out cleaning or maintenance operations on the lift.
- Always remember to periodically check the tightening and seal of the screws and couplings.
- Always use the recommended oils.
- Always remember to periodically check that the safety devices are in perfect condition and work efficiently.
- Always remember that maintenance work must be carried out on the lift only by qualified and skilled personnel with all due care by following the instructions given in this manual and replacing damaged or worn parts.
- Lifting and movement operations for lift parts or organs must be performed by following the procedures and using the lifting and slinging accessories prescribed by the regulations in force in the country of operation
  - Always completely remove all traces of oil from the floor as soon as they are noticed because they constitute a dangerous risk of fall.
- Always use original spare parts for repairs and maintenance.
- We recommend learning the instruction manual and keeping it within easy reach for the entire working life of the lift.

## 3. TRANSPORT, UNLOADING AND COMMISSIONING

### 3.1. TRANSPORT AND UNLOADING

The unloading/loading of the PONYBENCH to and from the transport vehicle must be performed only by means of fork-lift truck with adequate lifting capacity, referring to the weight specified in the table (SECTION 1 -1.8.TECHNICAL SPECIFICATIONS). For transport, the packing must be attached to the transport vehicle by means of appropriate retaining systems.

The PONYBENCH is appropriately packed by the manufacturer before delivery to the forwarding agent as follows: The lift and the control console and are normally placed inside a wooden crate wrapped in a transparent sheet of nylon shrink-wrap.

Unloading using other methods is strongly discouraged prohibited because there are no suitable points for gripping with lifting equipment.

During all handling operations, we recommend:

- Protecting the control console from exposure to inclement weather and always handling it with care. Whenever the console must be moved, before turning it upside down, remove the plug with the discharge hole from the tank and install the zinc-plated plug provided with the delivery of the lift and always removed during the first installation phase in its place.



**WARNING! It is prohibited to turn the PONYBENCH PR PLUS version control unit upside down during moving because the pneumatic-hydraulic pump may become unprimed.**

Protecting against cutting by sharp edges at the ends using adequate material (Pluriball-Cardboard).

During all operations with the fork lift, be careful to avoid damaging the hydraulic parts and the structure of the lift itself

### 3.2. UNPACKING

After removing packing, check that the appliance is in perfect condition, looking for any visibly damaged parts. In case of doubt, do not use the lift and contact professionally qualified personnel (your dealer).

Keep packing elements (plastic bags, polystyrene foam, nails, screws, wood, etc) out of the reach of children, as such objects are potentially hazardous. Dispose of these materials in the appropriate collection points, as they are not biodegradable.

### 3.3. INSTALLATION

Operations for installation of the PONYBENCH are described below.

Before starting installation, check that all parts are in perfect condition and that none are missing.



**WARNING! The installation, adjustment and testing of the PONYBENCH are dangerous operations and must be performed exclusively by qualified and authorised personnel capable of guaranteeing their work to the safety procedures applied in mechanical, electrotechnical, hydraulic, and pneumatic fields. Carefully read the instructions contained in this manual and contact the Manufacturer directly in case of doubt. SPANESI declines all responsibility for damage to persons, animals or property caused by failure to observe the safety precautions and accident-prevention directions given in this manual.**

#### 3.3.1. CHOOSING THE POSITION

The installation position of the PONYBENCH must be chosen by assessing the following factors:

- The position must be safe, free from obstructions and protected from atmospheric agents. From the control position, the operator must be able to see all the equipment and the surrounding area in order to prevent the presence of unauthorised persons or objects from creating risk.
- The area must be provided with good illumination. The room must be suitable for installation of the lift There must be no sources or work processes that can produce inflammable gases or vapours.
- The casing of the lift electrical system has a IP54 Protection Rating and is not suitable for operation in areas where inflammable gases and/or vapours or explosive mixtures may be released.
- The temperature of the room in which the lift operates must be between 15°C and 40°C
- The installation area must be smooth and level
- The area must be clean but don't leave the floor and the lift wet and don't use corrosive detergent.

### 3.3.2. PREPARING THE PIT (PONYBENCH PR PLUS 35)

The PONYBENCH is a fixed-type lift and must be installed in a pit created in dimensions previously requested from the Manufacturer.

Installation requires the checking and adaptation of both the technical systems in the bodyshop and the floor where the lift will be positioned.

**The following instructions for the execution of the foundation must be scrupulously respected:**

The lift's housing area (the pit's floor) must be flat and perfectly level (with a tolerance of 5 mm on the total length).

If possible, excavate the pit using an appropriate disk saw by cutting a trench in the dimensions provided in the drawing above.

The floor of the pit must be composed of a reinforced concrete casting with a load capacity of 250 kg/cm<sup>2</sup> using concrete of 250 RBK Class or higher.

- The casting of the pit floor must be no less than 200 mm deep and free from defect.
- The pneumatic and hydraulic connections from the control console containing the hydraulic unit to the lift must be laid underground in a stiff PVC pipe of no less than 60 mm minor diameter. One end of the pipe must be equipped with a PVC elbow union whenever possible.
- A straight line between the pit and the position established for the hydraulic unit control console must be traced on the floor to mark the path of the underground PVC pipe.
- Using a hammer drill or an appropriate disk saw (if the permitted by the nature of the floor), make a trench approx. 2 or 3 cm larger than the diameter of the PVC pipe. The depth of the trench must be sufficient to insert the free mouth of the elbow union end perfectly at the level of the floor.
- Assess the control console installation position: it must be far enough away from the lift and at the same time provide a good view of the work area.
- Before positioning the lift, a 10 cm. yellow perimeter band parallel to the sides of the pit no less than 10 cm wide must be laid on the floor around the lift. This band serves to mark the danger area. The distance between the internal border of the yellow band and the edge of the pit must be no less than 35 cm on all sides.
- SPANESI S.p.A. provides the connections required in a length of approx. 5 meters. This size is more than sufficient for most applications, but if longer length is required for the installation of the lift, the entire electrical connection must be redone without the splicing of cables. In this case, the efficiency of the earthing system must be checked by performing a continuity check on the equipotential protection circuit.

### 3.3.3. CONTROL OPERATIONS TO BE PERFORMED BEFORE INSTALLATION

Before installing the PONYBENCH, we recommend checking (and adapting as required) the utilities in the garage and taking the following measures:

- Install a pressure regulator-filter near the control consoles connected to the compressed air distribution network set to a pressure of 7-8 bar, otherwise provide an air storage tank that guarantees a minimum level of autonomy for the lift.



**WARNING! The compressed air pressure must be limited to 10 bar. If the safety valve on the system's compressor is set to a pressure of more than 10 bar, a pressure reduction - filtration - lubrication unit equipped with a gauge set to a working value of 8 bar must be installed on the compressed air unit supply Line.**

**Check the voltage and frequency, which must correspond to the voltage and frequency of the electric distribution network in the bodyshop.**

The lift's operating voltage is indicated in the manual in Point 1.8 - TECHNICAL SPECIFICATIONS. The electrical equipment is normally provided for operation at 400 Volts, 50 Hz frequency.

- Check the condition of the power supply wires and make sure that an earth wire is present.
- Make sure that there is a automatic sectioning device upstream for protection against overloads equipped with an overload cut-out.
- Check the control board due to power the hydraulic unit: it must be provided with three fuses and a correctly set thermal switch.
- Connect the cable to the device with the maximum attention in compliance with the regulations in force.



**DANGER! Never connect the lift electrical system directly to the bodyshop system eads: a fault in the latter's distribution system can seriously injure the operator and permanently damage the control unit.**

### 3.3.4. LIFT INSTALLATION

The equipment should be placed near the intended installation area.



**WARNING! Before beginning work, clean and remove any obstructions from the installation area. The area must be appropriately marked out to keep unauthorised personnel out. Check the condition and suitability of the available equipment. As these operations are dangerous, they must be performed by expert, responsible personnel. When using the lifting equipment, follow the safety regulations in force in the country where the machine is being used. Never touch lifted loads and do not stand within the operating range of the forklift truck.**

Take the lift from the warehouse in which it has been stored since arrival using a fork lift or any other adequate lifting equipment.

Remove packing with utmost care and position the equipment as follows:

- Bring the fork lift near the wooden crate, slide the fork between the lower part of the lift and the bottom of the crate
- Slowly raise the lift from the crate and position it on the floor in the installation area foreseen, being careful not to overturn the control console
- Take the control console from the movable platform of the lift and rest it at a certain distance from the lift in a safe position.
- Unscrew the screws on the control console using the appropriate setscrew wrench, remove the metal casing from the control console and the hydraulic unit, and position it in a safe place(Fig. 3b).
- The PONYBENCH is equipped with a single-acting jack that permits the movable platform to be raised without using the hydraulic unit.
- With the movable platform lowered, install 4 lifting eyebolts in the holes provided at the corners of the upper movable platform bed.
- Pass tie-rods with cables or chains through the 4 eyebolts previously prepared on the upper movable platform bed.
- Hang the tie-rods from the crane hook and lift slowly until the lift's upper movable platform is completely extended. Continue raising until the base is lifted approx. 20 cm from the floor.
- With the use of the lifting device, insert the lift into the pit prepared previously, being careful to avoid all damage.
- Slowly lower the crane until the anti-fall safety hook engages the last block provided in the lift base sheet (which corresponds to the lift's maximum lifting height).
- Keep the lift's movable platform hanging from the crane hook.

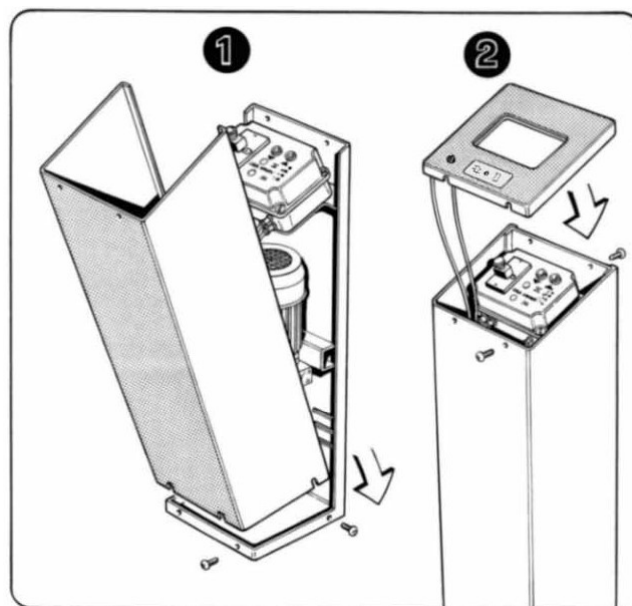

FIG 3b

- Use a power drill to drill 6 holes in the floor of the pit near the holes already made in the sheet at the base of the lift. Use jets of compressed air to clean these holes from residue.
- Insert the screw anchors into the respective holes one at a time and push them deep inside using a plastic mallet and then screw down.
- Tighten each screw anchor using a torque wrench or similar tool. If the wrench fails to reach the required tightening torque value, it means that the hole is too large or the consistency of the foundation onto which the hole has been drilled is insufficient. When in doubt, perform a new fixing using chemically- anchored bolts.
- Disconnect the various pipes and cables from the control console and pass them through the pit's previously prepared underground raceway until they emerge on the other side.



**WARNING! The imperfect or incorrect fastening of the lift's base in the pit can cause instability during operation and create the risk of vehicle falling and permanent deformation of the lift. Regularly check the efficiency of such fastening on the ground at the base of the lift.**

Proceed to the final positioning of the hydraulic unit control console by proceeding as follows (Fig. 3b PONYBENCH):

- Place the control console in its final position with the hydraulic unit positioned over the hole for the mouth of the stiff PVC pipe's elbow union laid underground in the floor that connects the lift housing pit to the control console itself.
- Make sure that the hole in the base of the control console is perfectly aligned with the mouth of the underground PVC pipe's elbow union.
- The control console is supported by 4 rubber pads: make sure that all 4 are perfectly positioned on the floor, otherwise adjust as required by screwing/ unscrewing.
- Do not insert the control console casing into the hydraulic unit yet: this operation must be performed only after completing all the connections.
- Wipe up any oil leaks on the floor or the base of the lift using a cloth.

### 3.4. CONNECTIONS

After installation, make the PONYBENCH connections with utmost care as follows.



**WARNING! It is very important for the various PONYBENCH connections to be connected correctly. Scrupulously follow the instructions and observe the diagrams provided below.**

#### 3.4.1. CONNECTING THE HYDRAULIC SYSTEM

Connect the lift's hydraulic system using the flexible pipe provided by proceeding as follows (fig. 4):

- Remove the black rubber flexible pipe from inside the lift. One of its ends is already connected to the lift's jack.
- After connecting the flexible pipe, be careful to avoid spilling oil because the hydraulic unit tank is supplied already filled by the manufacturer.
- Connect the automatic coupling at the end of the flexible pipe to the hydraulic control unit.

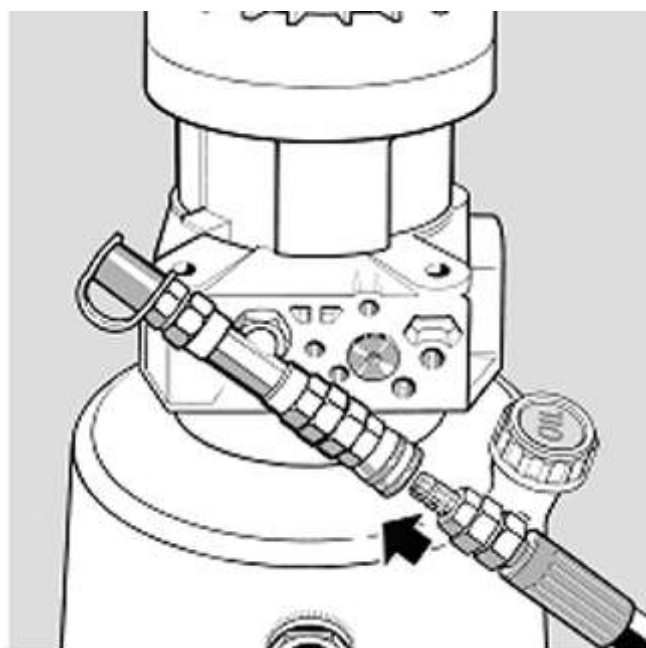

Figure 4

### 3.4.2. CONNECTING THE PNEUMATIC SYSTEM

Proceed as follows to connect the lift's pneumatic system (fig.5):

Take out the Rilsan compressed air flexible pipe. One end is already connected to the console. The other end is equipped with a male automatic coupling to be connected to the pipe fitting of the compressed air distribution system (we recommend first checking the compatibility between the connector and attachment and changing one or the other for the right compatibility if necessary).

We recommend installing a filter/pressure reduction unit in the compressed air line (see Par. 3.3.3 CONTROL OPERATIONS TO BE PERFORMED BEFORE INSTALLATION).

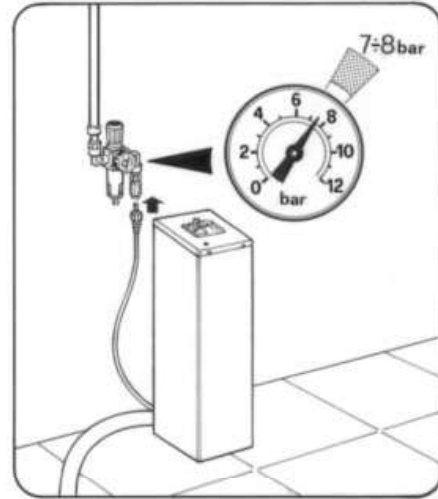

Figure 5

### 3.4.3. CONNECTING THE ELECTRICAL SYSTEM



**WARNING! Connect the lift's limit-switch wiring to the control unit distribution board before connecting the distribution board to the power supply terminal block.**

For correct connection to the lift electrical system, proceed as follows:

- Check the electrical distribution board powering the lift control unit: it must be provided with three fuses and a correctly set thermal switch.
- Check the lift operating voltage and frequency: they must correspond to the voltage and frequency of the bodyshop supply mains. The PONYBENCH operating voltage is specified in the plate on the control unit electric motor casing. The machine electrical equipment is designed to operate normally at 400 V 50 Hz.

#### 3.4.3.1. CONNECTING THE ELECTRICAL SYSTEM

For correct connection of the electrical distribution board in the control console, proceed as follows:

- Check the electrical distribution board powering the lift control unit. It must be provided with a set of three fuses and a correctly-set magneto-thermal switch.
- Together with the lift, SPANESI S.p.A. supplies a 2.5 m long cable. This length is generally sufficient for the connections.
- If it is impossible to position the control console close enough to use the cable provided, the whole cable must be re-done as follows:



**WARNING! Do not under any circumstances splice electrical cables to the power cable.**

- The power cable section must be adequate for the load absorbed by the lift and for the distance between the control console and bodyshop distribution board.
- Before connecting the control unit power cable to the distribution board, check that the distribution board switch is set to "0", otherwise open the contacts.
- The electrical power supply must be connected to the lift distribution board by passing the cable through the hole provided (1) until it reaches the terminal block marked with the power supply voltage.
- The three phase wires must be fixed to the respective terminals marked by the symbols L1, L2 and L3. The earth wire must be connected to the yellow-green earth.
- Complete the connection of the control unit to the distribution board and close the cover by means of the 4 respective screws.

**Check the correct electrical connection to the supply mains as follows:**

- Rotate clockwise and pull the mushroom-shaped emergency button until it is released (1).
- Press the reset button (2) on the right of the mushroom-shaped emergency button (1): the white pilot light (3) will come on to indicate



**WARNING! Always check the efficiency of the machine earthing system after connecting the power supply. Faulty or inadequate connection of the earth wire can cause serious injury and even death. Never connect the lift electrical system directly to the bodyshop system leads: a fault in the latter's distribution system can seriously injure the operator and permanently damage the control unit.**

### CONTROL Key

- 1 Master switch with self-retaining mushroom-shaped emergency stopbutton.
2. Reset button
3. Power-on pilot light.
4. Lift descent control button
5. Lift ascent control button
6. Lift mechanical safety release for 1st section
7. Lift mechanical safety release + microswitch By-Pass
8. Ascent pilot light
9. Descent pilot light
10. By-pass pilot light

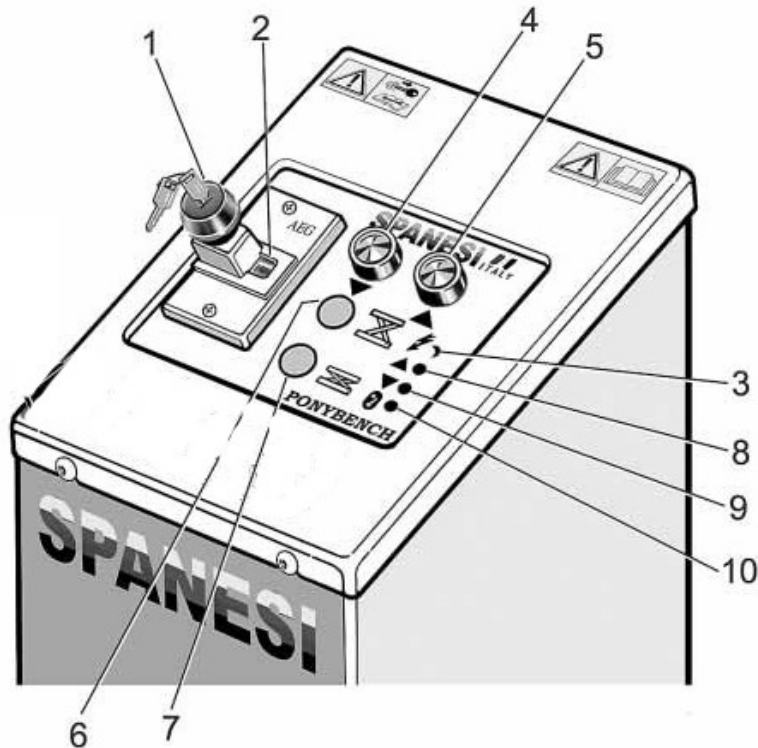

Fig. 6: PONYBENCH PR PLUS CONTROL CONSOLE PUSHBUTTON PANEL

### 3.4.3.2. CHECK MOTOR POLARITY

Before operation, motor polarity must be checked by proceeding as follows:

- Make sure that the key has been inserted in the mushroom-shaped emergency button.
- Rotate clockwise and pull the mushroom-shaped emergency button until it is released (1).
- Press the reset button on the right of the mushroom-shaped emergency button (2).
- Press the <ascent> button (5) for approx. 3 seconds: the lift should rise.



**DANGER! Always disconnect the lift whenever working on the power supply terminal block. Contact of parts of the body with live parts of the machine can cause serious injury and even death.**

If the lift fails to rise, change motor polarity by proceeding as follows:

- Disconnect voltage from the control unit using the corresponding switch on the distribution board.
- Press the mushroom-shaped emergency button (1) until it locks in its self retaining position.
- Open the control console pushbutton panel distribution board cover, disconnect Leads L1 and L3 from the terminals and invert their positions.

#### Screw the cover back in place.

- Reconnect voltage to the lift through the distribution board
- Rotate clockwise and pull the mushroom-shaped emergency button until it is released (1).
- Press the reset button on the right of the mushroom-shaped emergency button (2).
- Press the <ascent> button (5) for approx. 3 seconds: the lift should rise.
- After performing all the above operations, complete the procedure by replacing the control console casing on the control unit.
- Position the casing on the control console frame and lock it in place using the setscrews provided (Fig.3b). Position the pushbutton panel cover (2 - Fig.3b) above the control console and lock it in place using the setscrews

### 3.5. AFTER CONNECTION

After completing all the connections and control operations, install the lift by proceeding as follows:

- Remove any tools, screws, nuts or anything else left on the floor. The area must be perfectly clean and unobstructed.
- Clean up any traces of spilt oil on the floor. The area must be perfectly clean and unobstructed.

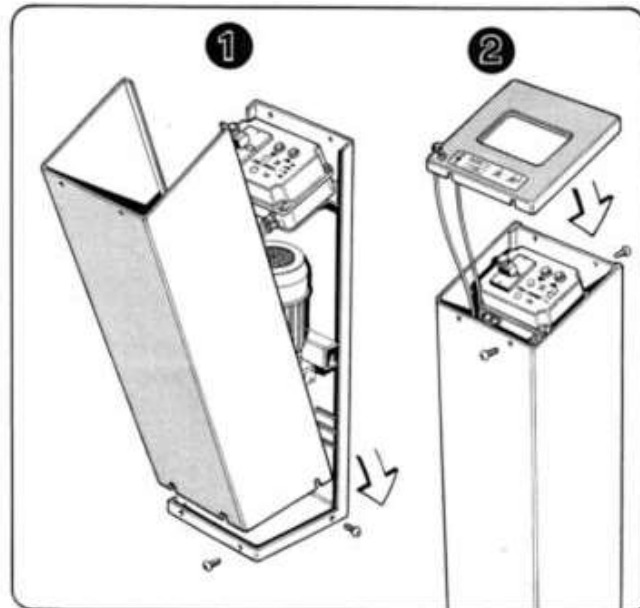

Figure 3b

## 4. USE INSTRUCTIONS

### 4.1. BEFORE USE



**WARNING!** Before starting PONYBENCH, check the efficiency of the system and get to know the control devices.

### 4.2. CHECKING OPERATION OF SAFETY DEVICES

Before beginning work, always check the correct operation of the safety devices provided by the manufacturer.

#### 4.2.1. EMERGENCY BUTTON

Check the correct operation of the mushroom-shaped emergency button as follows:

- Power the control unit by means of the switch placed on the power distribution board.
- Make sure that the key has been inserted in the mushroom-shaped emergency button.
- Rotate the mushroom-shaped emergency button clockwise until it is released (1).
- Press the reset button (2) on the right of the mushroom-shaped emergency button (1). The yellow pilot light (3) will come on to indicate that the equipment is powered.
- Press the <ascent> button (5) with one hand) and raise the movable platform.
- Keeping the <ascent> button pressed, use your free hand to press the red mushroom-shaped emergency button (1): the lift should immediately stop.

#### 4.2.2. RESET BUTTON

Check correct operation of the reset button as follows:

- Make sure that the key has been inserted in the mushroom-shaped emergency button.
- Rotate the mushroom-shaped emergency button clockwise until it is released (1).
- Press the <ascent> button (5): the lift should remain at a standstill.
- Press the reset button (2) on the right of the mushroom-shaped emergency button (1). The yellow pilot light (3) will come on to indicate that the equipment is powered.
- Press the <ascent> button again (5): the lift should move upwards.

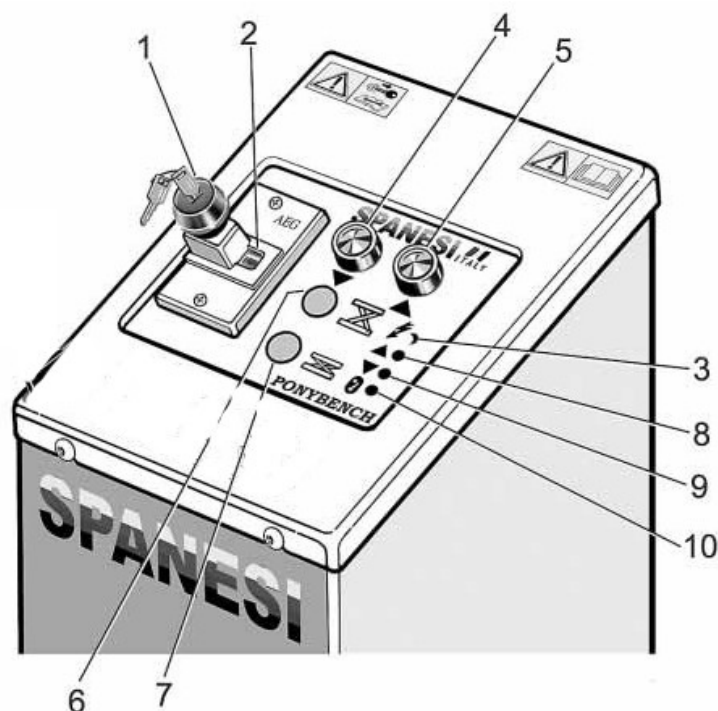

FIG.6 PONYBENCH-PR PLUS CONTROL CONSOLE PUSHBUTTON PANEL

#### 4.2.3. CHECKING OPERATION OF THE FALL-PROOF SAFETY HOOK

Check correct operation of the fall-proof safety hook according to the PONYBENCH version as follows:

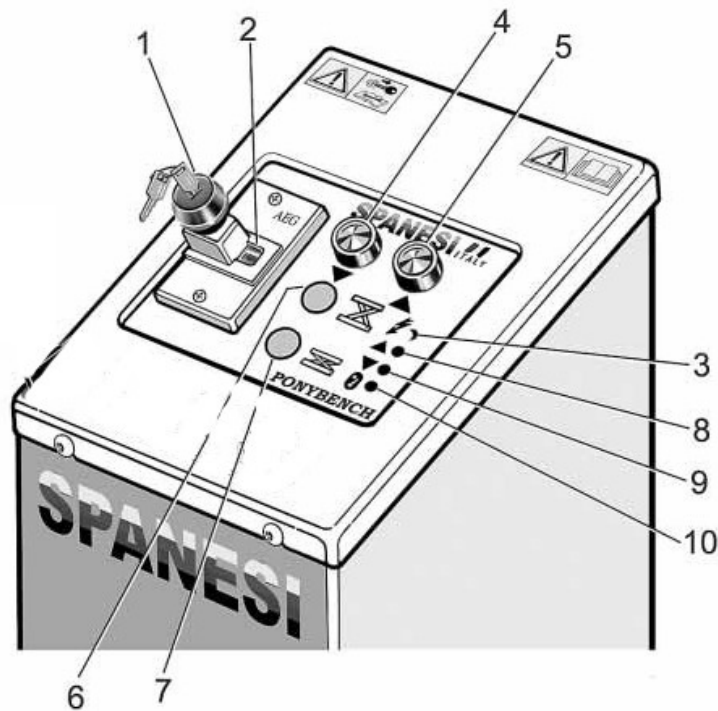

FIG.6 PONYBENCH-PR PLUS CONTROL CONSOLE PUSHBUTTON PANEL

PONYBENCH PR PLUS:

- Make sure that the key has been inserted in the mushroom-shaped emergency button.
- Rotate the mushroom-shaped emergency button clockwise until it is released (1). Press the reset button (2).
- Press the <ascent> button (5) until the lift rises to at least 60-70 cm above the floor. The fall-proof safety hook will rise automatically.
- Press the button for descent to the first section (6); the fall-proof safety hook (9- fig.2a) should be engaged by one of the steel blocks welded to the base sheet as the lift descends.

#### 4.3. USE OF THE LIFT

The PONYBENCH is used as a lift to facilitate the operations of sanding and/or disassembly/assembly of automobiles.



**WARNING! The lift must never be used to lift persons and/or animals.**

##### 4.3.1. RAISING THE PONYBENCH LIFT



**WARNING! The PONYBENCH PR PLUS can be used only by duly instructed and authorised personnel. Make sure that there are no persons and/or foreign objects in the work area before performing manoeuvres with the lift. Make sure that the vehicle is correctly positioned on the lift before proceeding to further operations.**

After checking the correct operation of the safety devices, the PONYBENCH PR PLUS lift can be used for work.

Check that the mobile platform is fully lowered.

Proceed as follows (fig. 6):

- Power the control unit by means of the switch on the power distribution board and make sure that the control console is connected to the compressed air system set to the correct pressure (see par. CONTROL OPERATIONS TO BE PERFORMED BEFORE INSTALLATION)
- Position the vehicle above the lift's movable platform.
- Position the vehicle on the lift in such way that its weight is distributed as evenly as possible.
- Any doors present must be closed.
- There must be no objects protruding from the vehicle



**WARNING! Remember that when parts of the vehicle are dismantled, the centre of gravity is altered. This must be taken into account when positioning the vehicle on the lift.**

- Before raising the lift, check that there are no persons and/or animals less than one meter from the perimeter of the lift or vehicle.
- Rotate the mushroom-shaped emergency button clockwise until it is released (1).

- Press the reset button (2) on the right of the mushroom-shaped emergency button (1). The yellow pilot light (3) will come on to indicate that the equipment is powered.
  - Press the <ascent> button (5).
  - Raise the vehicle around 30 cm above the ground, and then stop movement. Check the stability of the vehicle, and then continue raising the lift by pressing the <ascent> (5) button again until the required height is reached. Release the button: the lift will stop in the required position. If the height of the premises where the PONYBENCH-BR PLUS, is installed is insufficient, be careful not to crush the vehicle against the ceiling when raising the lift.
- After every operation to raise the lift, the PONYBENCH-BR PLUS, must always be set to the safety position as follows:
- Press the <descent> button (4) and keep it pressed until the lift comes to a stand still on the anti-fall safety hook's first steel safety stop block.



**WARNING! If a dangerous situation occurs during lift manoeuvres, immediately press the red emergency stop mushroom-shaped button.**

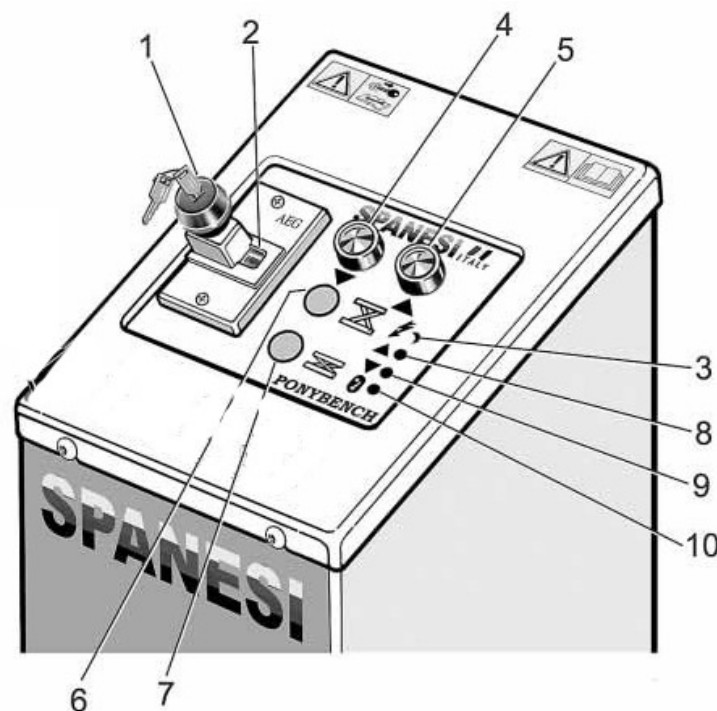

FIG.6 PONYBENCH-PR PLUS CONTROL CONSOLE PUSHBUTTON PANEL

#### 4.3.2. LOWERING THE PONYBENCH LIFT

The lift is lowered as follows (Figure 6):

- **DESCENT TO FIRST SECTION**
- **COMPLETE DESCENT.**

##### DESCENT TO FIRST SECTION



**WARNING!** Before lowering the lift, make sure that there are no persons, animals or property that may remain trapped or crushed below if the vehicle falls.



**WARNING!** The base of the lift to which the fall- proof safety hook is attached must always be free from all obstacle.



**WARNING!** Before lowering the lift, always make sure that there are no pipes or power tool cables in the vicinity that may be crushed.

Proceed as follows for <descent to the first section>

- Press the <ascent> button (5) and keep it pressed until the fall-proof safety hook is released.
- The base of the lift to which the fall-proof safety hook is attached must always be free from all obstacle.
- Press the <descent> button (4) and the <descent to first section> button (6) at the same time: the movable platform should descend.
- Keep both buttons (4) and (6) pressed down until the PONYBENCH PR PLUS automatically stops at a height of 30-35 cm by the triggering of the stroke-end safety micro switch.



**WARNING!** If a dangerous situation occurs during lift manoeuvres, immediately press the red emergency stop mushroom-shaped button.

##### COMPLETE DESCENT



**WARNING!** Before continuing descent all the way to the ground, make sure that there are no persons, animals or property that may remain trapped or crushed below if the vehicle falls.



**WARNING!** The base of the lift to which the fall- proof safety hook is attached must always be free from all obstacle.



**WARNING!** Before lowering the lift, always make sure that there are no pipes or power tool cables in the vicinity that may be crushed.



**WARNING!** In the event of danger or a critical situation while using the lift, always immediately press the mushroom-shaped emergency stop button.

Proceed as follows in order to complete descent:

- Press both the <descent> button (4) and the <final descent> button (7) at the same time: the movable platform will continue descending (if the lift is already at a height that is lower than the stroke-end micro switch intervention height, press the <ascent> button (5)).
- Keep both buttons (4) and (7) pressed until the platforms reach the floor/ the frame of the basement.
- Once the descent has been completed, press the mushroom-shaped button (1) before leaving the control console.

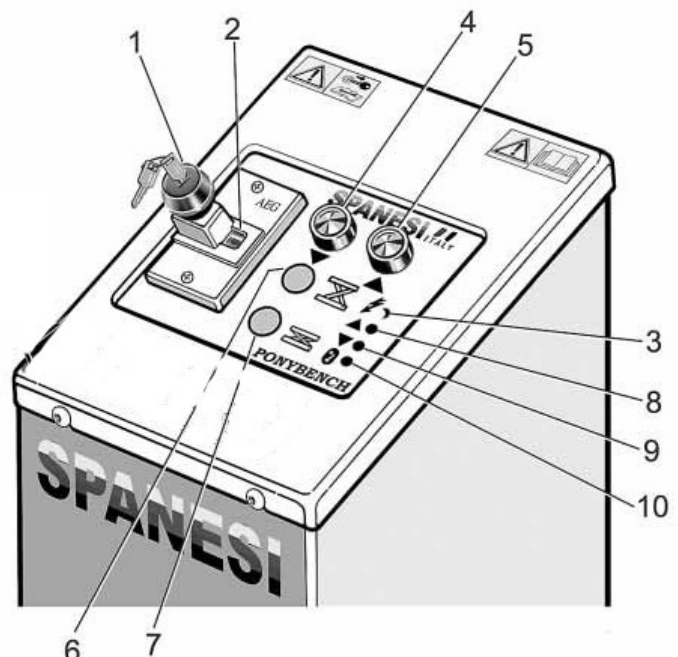

FIG.6 PONYBENCH-PR PLUS CONTROL CONSOLE  
PUSHBUTTON PANEL

## 5. SAFETY DEVICES

### 5.1. SAFETY DEVICES PONYBENCH

The PONYBENCH is provided with several safety devices for protecting the operator.



**WARNING! The following devices must under no circumstances be tampered with or removed. They must be regularly checked and always kept in perfect working order.**

The following safety devices have been installed to ensure that the operator always works in complete safety under all conditions:

- **NON-RETURN MECHANICAL SAFETY DEVICE**
- **EMERGENCY STOP BUTTON**
- **SAFETY LOCK VALVE**
- **RESET BUTTON**
- **MAGNETO-THERMAL OVERLOAD CUTOUT**
- **LOW VOLTAGE CONTROLS ELECTRICAL CIRCUIT**
- **SAFETY WARNING SIGNS**

### 5.2. NON-RETURN MECHANICAL SAFETY DEVICE

This prevents the descent of the lift even in the event of a breakdown in the lifting system or whenever intervention must be made on the hydraulic jack.

The system consists of a movable hook controlled by a pneumatic cylinder which automatically stops in the safety stops at the base of the lift. The operator is obliged to always position the lift in <safe> before performing operations on the vehicle.

### 5.3. EMERGENCY STOP BUTTON

When pressed, it stops all movements instantly. After being pressed, it remains locked in position by the mechanical self-retaining device.

### 5.4. SAFETY LOCK VALVE

It prevents the lift from coming down in the event of breakage of the delivery flexible pipe that connects the lifting jacks to the electro-hydraulic unit. This valve is of the <normally open> type and positioned directly on the mouth of the liner of the jack upstream from the connection to the flexible pipe that connects the jack to the electro-hydraulic unit and automatically intervenes whenever for any reason a strong pressure difference is created between the valve inlet and outlet mouths, such as when a flexible pipe suddenly breaks.



**DANGER! Alteration of the safety lock valve poses a serious risk to the safety of the operator and the structural integrity of the PONYBENCH lift and automatically invalidates the warranty.**

### 5.5. RESET BUTTON

It prevents movement when there is a power failure for any reason or when the emergency button has been pressed. Once the emergency button has been released, the reset button restores power to the control unit.

### 5.6. LOW VOLTAGE CONTROLS ELECTRICAL CIRCUIT

It minimises electrical risks during use of the push-button panel. It consists of a safety transformer, which lowers the voltage of the auxiliary circuit powering the control console to 24 V AC.

### 5.7. MAGNETO-THERMAL OVERLOAD CUTOUT

It cuts off the power supply to the electric motor terminals in the event of motor overload and/or overheating. It consists of a magneto-thermal contactor set to the electrical input value established by the motor manufacturer.

### 5.8. SAFETY WARNING SIGNS

They indicate a danger, a prohibition or directions to be followed to ensure operator safety and correct operation of the PONYBENCH.

### 5.9. DEVICE TO STOP WHEELS

This device doesn't allow the rolling of the vehicle wheels.

## 6. LIFT ACCESSORIES

### 6.1. STANDARD ACCESSORIES

The PONYBENCH-PR PLUS lift is delivered to the user complete with all the standard accessories that permit efficient and productive operation under all conditions. The standard equipment varies for the two models and is composed as follows:

#### 6.1.1. PONYBENCH STANDARD ACCESSORIES

The PONYBENCH is provided complete with all the standard accessories that will permit the user to operate the lift with the greatest efficiency and performance under all conditions.

The lift is usually delivered with the following (Fig. 2a):

- 1 electro-hydraulic scissors lift.
- 4 wheel platform.
- 1 control console with electro-hydraulic unit (4).
- 1 set of flexible pipes for connections between the lift and the control console
- 1 instruction manual.
- 1 EC declaration of conformity.



**DANGER!** The PONYBENCH PR PLUS lift cannot be used inside painting ovens/booths (see the regulations in force in the nation of use). SPANESI S.p.A. declines all responsibility for damage to persons, animals or property due to negligence or failure to comply with these instructions.

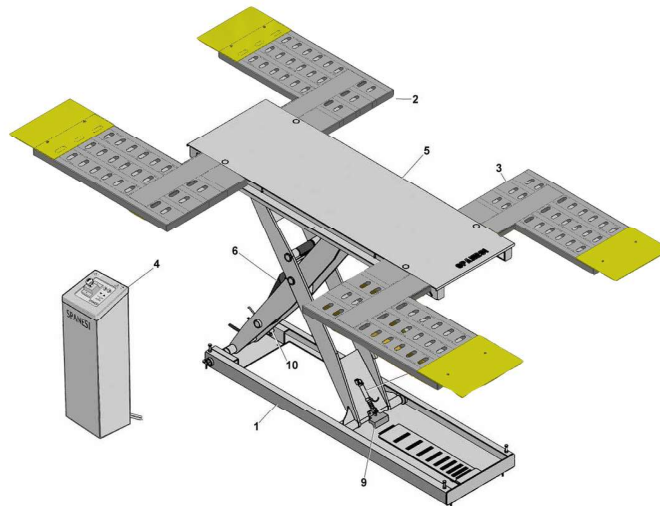

Figure 2a : PERSPECTIVE VIEW OF THE PONYBENCH-PR PLUS

## 7. SYSTEMS

The PONYBENCH-PR PLUS is electro-hydraulically operated. The power supply is electricity for the former and compressed air for the latter. The lift is raised up and down by gear pump.

### 7.1. PONYBENCH PR PLUS LIFT HYDRAULIC DIAGRAM

The operating diagram of the PONYBENCH PR PLUS hydraulic system consists of a circuit with the following main components:

- 1) Lift control gear pump
- 2) Electric motor
- 3) Main pressure relief valve
- 4) Pump/motor coupling
- 5) Suction filter
- 6) Unidirectional valve
- 7) Quick fit pressure gauge connection
- 8) Flow control valve
- 9) 2-way/2-position solenoid valve, ascent/descent control
- 10) Safety lock valve (against pipe breakage)
- 11) Single-acting jack for lift control
- 12) Control unit tank
- 13) Electrohydraulic unit

#### · OPERATION



**WARNING!** Alteration of the relief valve will seriously damage the PONYBENCH- PR PLUS. SPANESI S.p.A. declines all responsibility for injury to persons and animals or damage to property due to alteration of this valve.

By enabling the ascent control, the electric motor (2) rotates the pump (1), the oil under pressure is conveyed to the plunger chamber of the jack (11) and passes through the safety lock valve (10), thus raising the movable platform.

When the lift must be lowered, the solenoid-valve (9) is energised and connects the air duct to the outlet, permitting the oil to flow to the tank (12). The flow control valve (8) controls the flow of oil from the jacks thus keeping the descent speed within the limits provided for by the manufacturer.

The main pressure relief valve (3) prevents the pressure from exceeding the value established by the manufacturer. The main pressure relief valve (3) must not be tampered with for any reason.

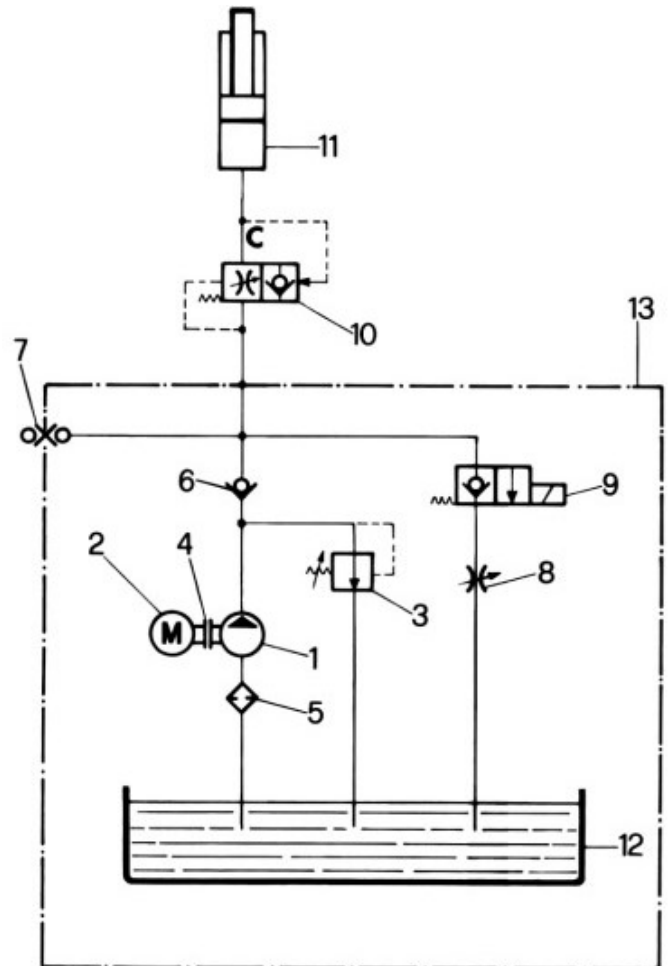

## 7.2. WIRING DIAGRAM

The operating diagram of the PONYBENCH-PR PLUS electrical system consists of a main power circuit and a low voltage auxiliary control circuit consisting basically of:

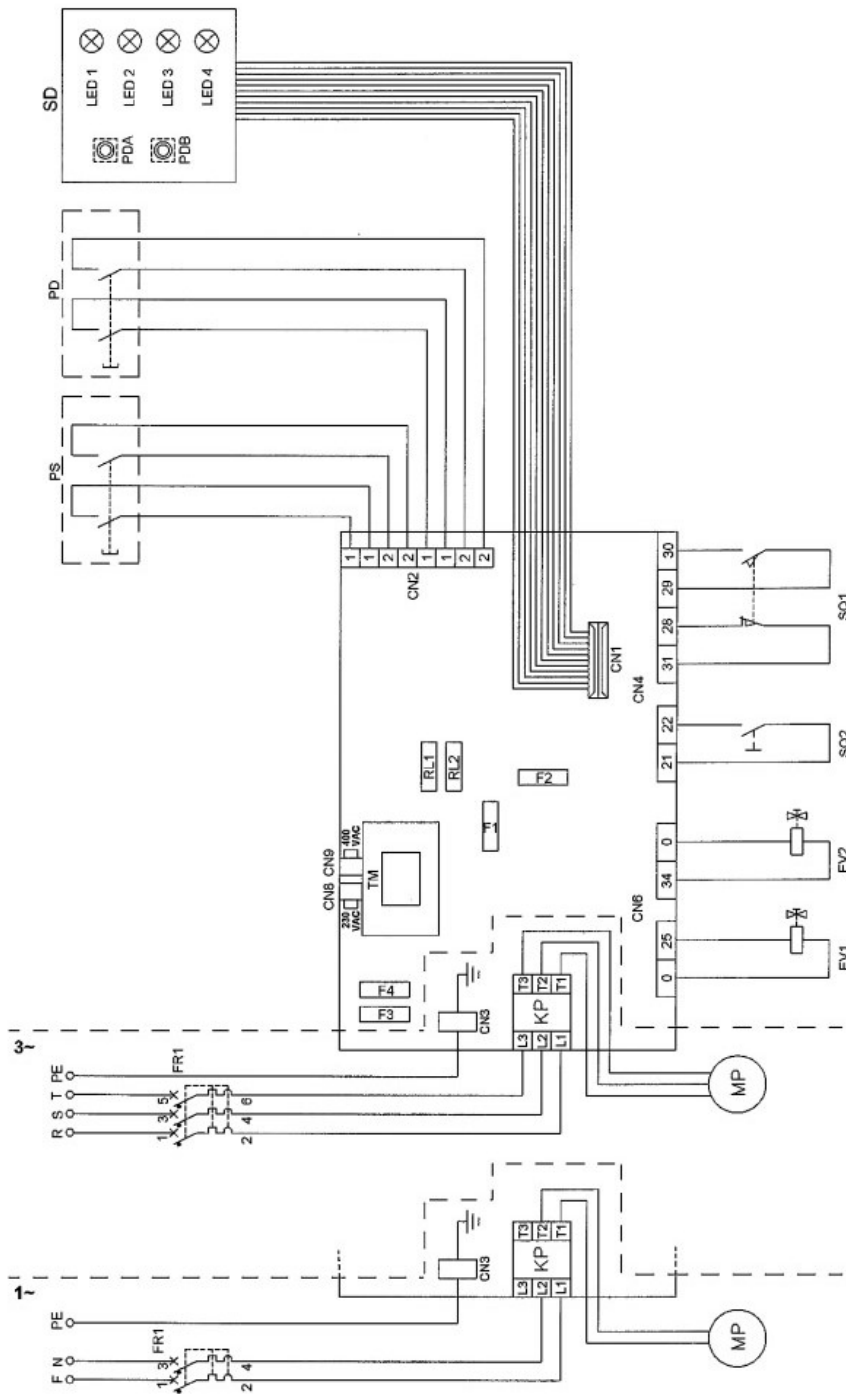

<b>Key</b>			
MP)	Motor of hydraulic control unit, power 1.5 Kw - 4 poles.	PD)	<Descent> push-button.
FR1)	Motor overload cut-out switch with mushroom head release and reset push-button.	SQ2)	Safety pressure switch
EV1)	Pneumatic solenoid-valve controlling release of anti-fall safety device hook.	SQ1)	Safety limit-switch controlling descent mode.
EV2)	Hydraulic solenoid-valve controlling lift descent.	PDA)	High descent push-button .
KP)	3-pole contactor + 24 volt auxiliary for electric pump motor.	PDB)	Low descent push-button .
TM)	Transformer, 50 volt-ampere, 400-230/24 volt.	LED1)	Power on pilot light
PS)	<Ascent> push-button.	LED2)	Ascent pilot light
		LED3)	Descent pilot light
		LED4)	Release pilot light
		F1-F2)	3.15A 5x20 fuses (secondary circuit)
		F3-F4)	1A 6.3x31 fuses (primary circuit)

- OPERATION:

When the contacts of the master switch (FR1) are closed, the current flows in both circuits. The transformer (TM), connected to two phases of the power circuit by means of the two-pole knife switch fuse-carrier (F3-F4) lowers the voltage from 400/230 V to 24 V in order to feed the auxiliary circuit. In this way only the control unit motor power supply circuit is powered by the line voltage 400/230.

The pump is rotated by the electric motor when the contacts of the contactor (KP) are closed by the use of the <ascent> (PS) or <descent> (PD) buttons. The closing of the <ascent> button contacts also energises the <ascent> solenoid (EV1) of the hydraulic solenoid valve at the same time.

The closing of the <descent> button contacts simultaneously energises the <descent> solenoid (EV2) of the hydraulic solenoid valve and the solenoid (EV1) of the pneumatic solenoid valve that releases the safety hook.

The auxiliary control circuit is disabled when the contacts of the mushroom-shaped emergency (FR1) that stop all movement are opened by the operator. This disconnects voltage from both the auxiliary circuit and the motor of the electrohydraulic unit (MP). In order for normal system operation to return, the mushroom-shaped emergency button must be released and the and the magneto-thermal overload cutout (FR1) must be reset.

## 8. MAINTENANCE

---

The PONYBENCH does not require any particular maintenance because the pins and sliding surfaces operate on long-life self-lubricating bushes. You are nevertheless advised to constantly monitor the lift and take immediate action whenever faults, unusual wear or breakage occur.

### 8.1. ROUTINE MAINTENANCE

In order to ensure the efficiency of the PONYBENCH lift and its correct operation, the observance of the instructions below is indispensable and the routine cleaning and maintenance described must be regularly performed to guarantee the best operation and use.

All cleaning and routine maintenance operations must be performed exclusively by authorised personnel observing the instructions provided below in conditions of complete safety.



**CAUTION! The frequencies of the various maintenance operations listed below are a guide and refer to normal operating conditions. Conditions can vary in relation to the type of service, frequency of use and the surrounding conditions in which the PONYBENCH- PR PLUS lift is used. If the lift is used in heavy duty conditions, maintenance must be increased. When topping up the level, changing the oil or greasing, always use the same type of lubricant previously used. The grease points must be thoroughly cleaned with compressed air before lubrication to prevent dust, dirt or foreign bodies mixing with the lubricant.**

#### 8.1.1. ONCE A DAY:

- Before starting work, check the operation of the emergency stop button.
- Check the correct operation of the microswitch that stops the lift at the first section of descent by running an ascent-descent cycle.
- Make sure that there is no leakage of oil from the lift jack and connection pipes (contact your local dealer whenever leakage is observed).

#### 8.1.2. WEEKLY:



**CAUTION! When topping up the level, changing the oil or greasing, always use the same type of lubricant previously used. The grease points must be thoroughly cleaned with compressed air before lubrication to prevent dust, dirt or foreign bodies mixing with the lubricant.**

- Grease the safety hook's sliding and hinging points through the greaser provided on the hook itself.
- Check the oil level in the control unit tank: it must be near the filling/inspection plug.

If necessary, top up the tank with hydraulic oil (such as ESSO NUTO H 46) via the filling/inspection plug hole. For this operation you are always advised to use the same type of oil.

If you wish to use oil of the same type but a different brand, you are advised to wait until the oil change.

#### 8.1.3. ONCE A MONTH

- Check the tightening of the fixing bolts at the base of the lift.
- Check the condition of the structures and parts of the PONYBENCH PR PLUS subject to wear and if necessary replace the worn or damaged parts. Always use original spare parts.

#### 8.1.4. ONCE EVERY TWO YEARS:



**WARNING! Observe the laws in force in the country where the appliance is being used as regards use and disposal of the products used for cleaning and maintenance, observing the prescriptions recommended by the manufacturers of these products.**

Change the system's hydraulic oil.

### 8.2. EXTRAORDINARY MAINTENANCE



**WARNING! If dismantling the machine at the end of its working life, observe the anti-pollution laws in force in the country where the machine is being used.**

Extraordinary maintenance (repairs of parts or assemblies) must be affected only by specialised personnel authorised by the Manufacturer.

Work on the hydraulic and electrical system, however minor, are considered extraordinary maintenance operations, because they must be performed by highly specialised personnel. Requests for such work must be sent directly to SPANESI S.p.A. by e-mail (preferably telephoning as well), specifying the type of request or problem and the lift's serial number (shown on the identification plate Figure 1).

### 8.3. PLACING THE EQUIPMENT OUT OF USE

Whenever the equipment will be placed out of use for a long period of time, the following operations must be performed:

- Disconnect all power supplies.
- Drain the tanks from their operating fluids.
- Provide the parts that might be damaged by dust infiltration with protection against the same.
- Grease all the parts that might be damaged if they dry out, such as the exible hydraulic or pneumatic pipe, etc;

When re-starting the equipment after a long period of inactivity, check to make sure that no cracks or cuts have emerged in the oil pipes and that themachine is in generally good working condition.

Check the operation of safety and intervention limit- switches and the fall proof safety hook.

### 8.4. SCRAPPING

Whenever the user decides to no longer use the PONYBENCH, we recommend making it harmless by draining the hydraulic oil from the hydraulic unit tank and the jacks that drive the lift.

Given that the machine is considered special waste, it must be disassembled and separated into similar parts that must be eliminated in compliance with the laws in force in the nation in question.

## 9. TROUBLESHOOTING

### 9.1. FAULTS, CAUSES AND SOLUTIONS

FAULT	POSSIBLE CAUSE	SOLUTION
The PONYBENCH lift does not work: no reaction.	No power	Check the power distribution board and if necessary set the master switch to the correct position.
		Check the position of the mushroom-shaped button on the control console; if necessary release it and then press the reset button
		Press the master switch placed on the power board in order to turn off power and then open the control panel on the control unit and check the condition of the fuses. Replace the fuses if necessary.
When the <ascent> is operated, the lift does not rising or rises with difficulty.	Electric motor burnt out.	Replace the electric motor.
	Pump not operating.	Pump not operating.
	Not enough oil in the control unit tank.	Check oil level in tank and, if necessary, top up.
Insufficient lift carrying capacity	Pump very worn.	Replace the pump.
	Ascent-descent control solenoid-valve jammed or out of service.	Check the solenoid-valve and, if necessary, replace it.
The lift descends by itself from stationary position until the safety hook catches and stops on a stop block	Insufficient hydraulic circuit operating pressure.	Check pump operating pressure on the pressure gauge. Replace the pump if necessary.
	Defective jack: defective sealing gaskets	Replace the jack.
	Safety lock valve worn.	Replace the valve.

## 10. SPARE PARTS

Orders for spare parts orders must be made solely to:



**Spanesi S.p.A.**  
 Via Praarie 56/II, Loc. Cavino  
 35010 S.G. delle Pertiche (PD)  
**Servizio Assistenza Tecnica**  
 tel.: (0039)049 9333211  
 Fax: (0039) 049 5741295  
 e-mail: spanesi@spanesi.it  
 web: www.spanesi.com

and must contain the following information:

- Lift model and serial number, year of manufacture. These data are on the identification plate (Fig. 1a-1b).

**SPANESI** S.p.A. Made in Italy   
 Via Praarie 56/II - S. Giorgio d. Pertiche (PD) - ITALY  
 Tel. +39 049 9333211 - Fax +39 049 9333210

<b>MOD.</b> <i>type</i>	Ponybench PR 35	<b>PRESS. MAX.</b> <i>max. pressure</i>	<b>310 bar</b>
<b>N° MATR.</b> <i>serial n.</i>		<b>PORTATA MAX.</b> <i>max. load</i>	<b>3500 kg</b>
<b>VOLT</b>	<b>230 V 3 Ph</b>	<b>HERTZ</b>	<b>50 Hz</b>
<b>ANNO</b> <i>year</i>	<b>2022</b>	<b>MASSA</b> <i>weight</i>	<b>675 kg</b>

Figure 1a

**SPANESI** S.p.A. Made in Italy   
 Via Praarie 56/II - S. Giorgio d. Pertiche (PD) - ITALY  
 Tel. +39 049 9333211 - Fax +39 049 9333210

<b>MOD.</b> <i>type</i>	Ponybench PR PLUS 35	<b>PRESS. MAX.</b> <i>max. pressure</i>	<b>310 bar</b>
<b>N° MATR.</b> <i>serial n.</i>		<b>PORTATA MAX.</b> <i>max. load</i>	<b>3500 kg</b>
<b>VOLT</b>	<b>230 V 3 Ph</b>	<b>HERTZ</b>	<b>50 Hz</b>
<b>ANNO</b> <i>year</i>	<b>2022</b>	<b>MASSA</b> <i>weight</i>	<b>675 kg</b>

Figure 1b

- The code of the requested part - for this data item, consult the drawings below.
- Description of part and quantity required.
- Shipment means and procedures.

If the latter item is not specified, although SPANESI S.p.A. pays particular attention to this service, it will not be responsible for any shipment delays due to force majeure. If the guarantee has expired or is void, unless otherwise specified, the consignee will always be charged for shipment expenses. Goods are shipped at customer's risk even if sold carriage free. Exploded drawings designed to help identify replacement parts can be found on the following pages.

### 10.1. DRAWING 1: PONYBENCH LIFT EXPLODED DRAWING

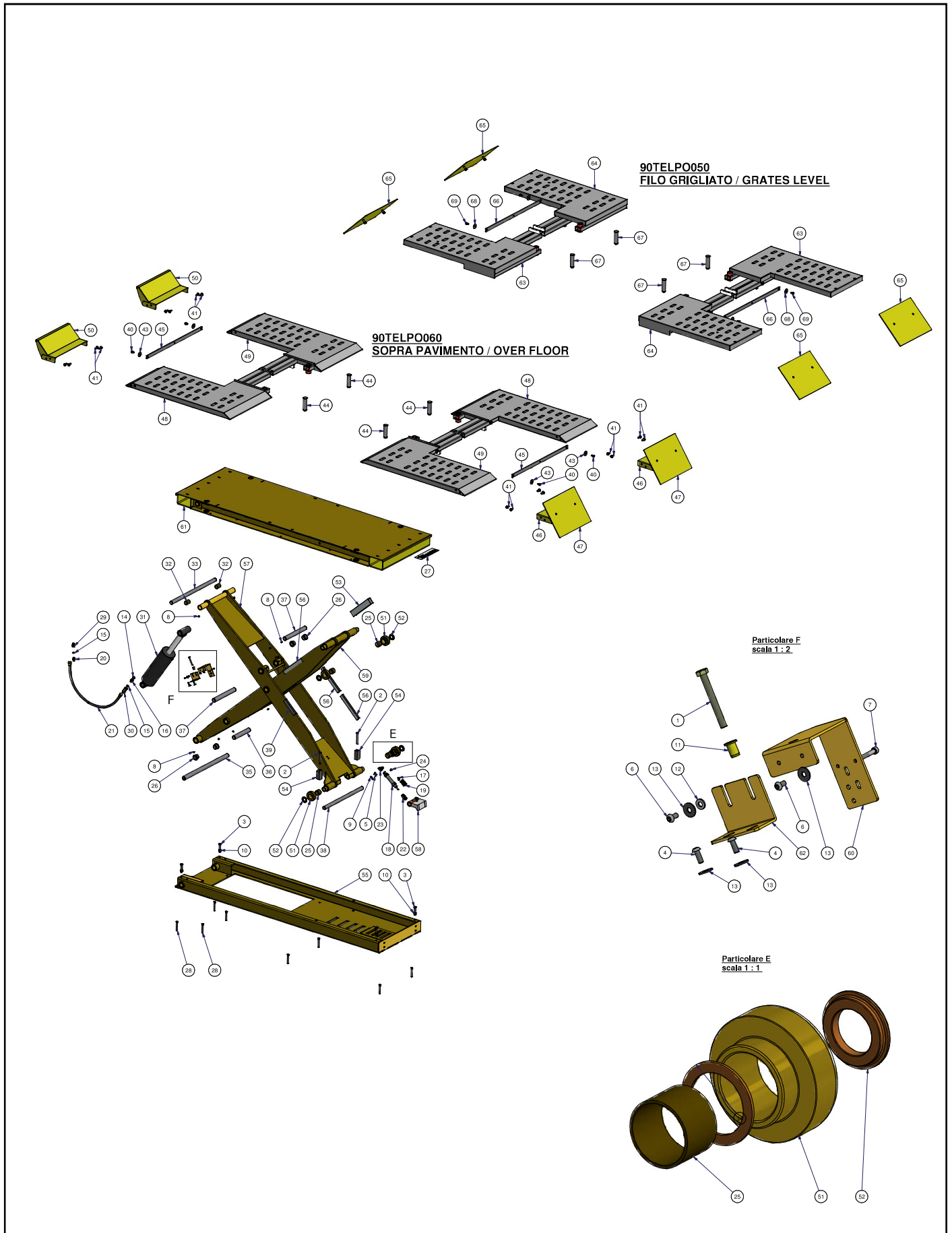

N°	CODE	DESCRIPTION	Q.TY
1	10030056	VITE TE M 8x 70 UNI5739 8.8	1
2	10030141	VITE TE M12x 100 UNI 5737	2
3	10030169	VITE TE M12x 70 UNI5739 8.8	4
4	10030400	VITE TBEI M 6x16 UNI7380	2
5	10030404	VITE TE M 6x 20 UNI 5739 8.8	2
6	10030405	VITE TBEI M 6x12	2
7	10030525	VITE TCEI M 5x 35 UNI5931	2
8	10030718	VITE STEI M 8x 10 UNI5927	9
9	10031017	DADO E M 6 FLANGIATO	2
10	10031024	DADO E M12x1,75 UNI 5587 ALTO	4
11	10031315	INS.TC M 8-030 L=16,0 RK01	1
12	10032108	ROND. DENTEL. EST. D. 6-13	1
13	10032509	ROND. PIANA D. 6x18 UNI6593-69	4
14	10032821	ROND. BONDED 3/8"	1
15	10032824	ROND. BONDED 1/4"	3
16	10037210	NIPPLE M 1/4-3/8	1
17	10037345	RACC. 90° D.6 1/8 FISSO RAPIDO	1
18	10037353	CILINDRO 1280 25 0050 PNEUMAT.	1
19	10037354	MOLLA ZN GIALLA PER MINIBENCH	1
20	10037360	NIPPLE 1/4-1/4 OLEOD.	1
21	10037362	TUBAZ. R7 TA 1/4 L=5000 FD+FD	1
22	10037366	FORCELLA 1302.32.13/1F	1
23	10037367	CERNIERA D 20/25 1200.20.03	1
24	10037372	SILENZIATORE 1/8" 2901 1/8	1
25	10038225	BOCCOLA AUTOLUBR. 40/44 H 30	4
26	10038226	BOCCOLA AUTOLUBR. 35/39 H 26	4
27	10041001	ADESIVO SPANESI GRANDE	1
28	10045036	TASSELLO HSU3- C8 x 85 TPSTORX	8
29	10060020	INNESTO RAPIDO IR 06 PM M 1/4	1
30	10060258	VALVOLA STROZZATRICE VUBA 3/8	1
31	10060276	CILINDRO DOPPIO EFFETTO SL170 50q/PONY 35q ( 300 BAR)	1
32	50103937	BOCCOLA AUTOLUBR. 30/34 H 40	2
33	50104424	PERNO D.30 L= 636 C45	1
34	50104437	SPESSORE 2mm D.54/40,5	2
35	50104587	PERNO D.35 L= 627 C45	1
36	50104588	PERNO D.35 L= 219 39NiCrMo3	1
37	50104589	PERNO D.35 L= 298 39NiCrMo3	2
38	50104591	PERNO D.30 L= 550 C45	1
39	50104617	LAMIERINO PASSATUBI L= 150 PONYBENCH ZN BIANCA	1
40	10030185	VITE TE M10x 16	4
41	10030430	VITE M10x25 ROND.ZIGRIANTA ZN BIANCA	16
42	10031328	INS.TC M10-030 L=22 RF41 ESAGONALE TESTA SVASATA RID.	4
43	10032516	ROND. PIANA D.10x40 UNI6593-69	4

44	50142205	PERNO PEDANE	4
45	70142206	RITEGNO PEDANE PONYBENCH PR	2
46	70142220	LAMIERA FERMARUOTA ANTERIORE PEDANA PONYBENCH	2
47	70234705	COMP. PEDANA FERMO RUOTA	2
48	70268975	CONP.PEDANA ANT.SX / POST DX PONYBENCH	2
49	70268980	COMPOSTO PEDANA ANT.DX/POST.SX PONYBENCH PR PLUS	2
50	70268985	COMP. FERMARUOTA POSTERIORE PEDANA PONYBENCH	2
51	50107422	RUOTA DI SCORRIMENTO	4
52	50107423	TAPPO RUOTA	4
53	50128943	LAMIERINO PASSATUBI PONYBENCH 250-30	1
54	50139351	BLOCCHETTO LIMITATORE ALZATA PONYBENCH CON PIANALE ALLUNGATO	2
55	70209490	COMP. BASE PONYBENCH	1
56	65104606	LAMIERINO PASSATUBI PONYBENCH	3
57	70209495	COMP. LEVA EST. PONYBENCH	1
58	65209520	COMP. SICURA	1
59	70209500	COMP. LEVA INTERNA PONYBENCH PLUS	1
60	70104605	LAMIERA SUPPORTO MICRO	1
61	70209505	COMP. PIATTAFORMA MOBILE PONY BE-BP	1
62	70104616	LAMIERINO PER MICRO	1
63	70266795	COMPOSTO PEDANA ANT.SX/POST.DX PONYBENCH PR PLUS 3500KG -	2
64	70266790	COMPOSTO PEDANA ANT.DX/POST.SX PONYBENCH PR PLUS - 3500kg	2
65	70234705	COMP. PEDANA FERMO RUOTA	4
66	70142206	RITEGNO PEDANE PONYBENCH PR	2
67	50142205	PERNO PEDANE	4
68	10032516	ROND. PIANA D.10x40 UNI6593-69	4
69	10030185	VITE TE M10x 16	4

## 10.2. EXPLODED VIEW OF PONYBENCH LIFT

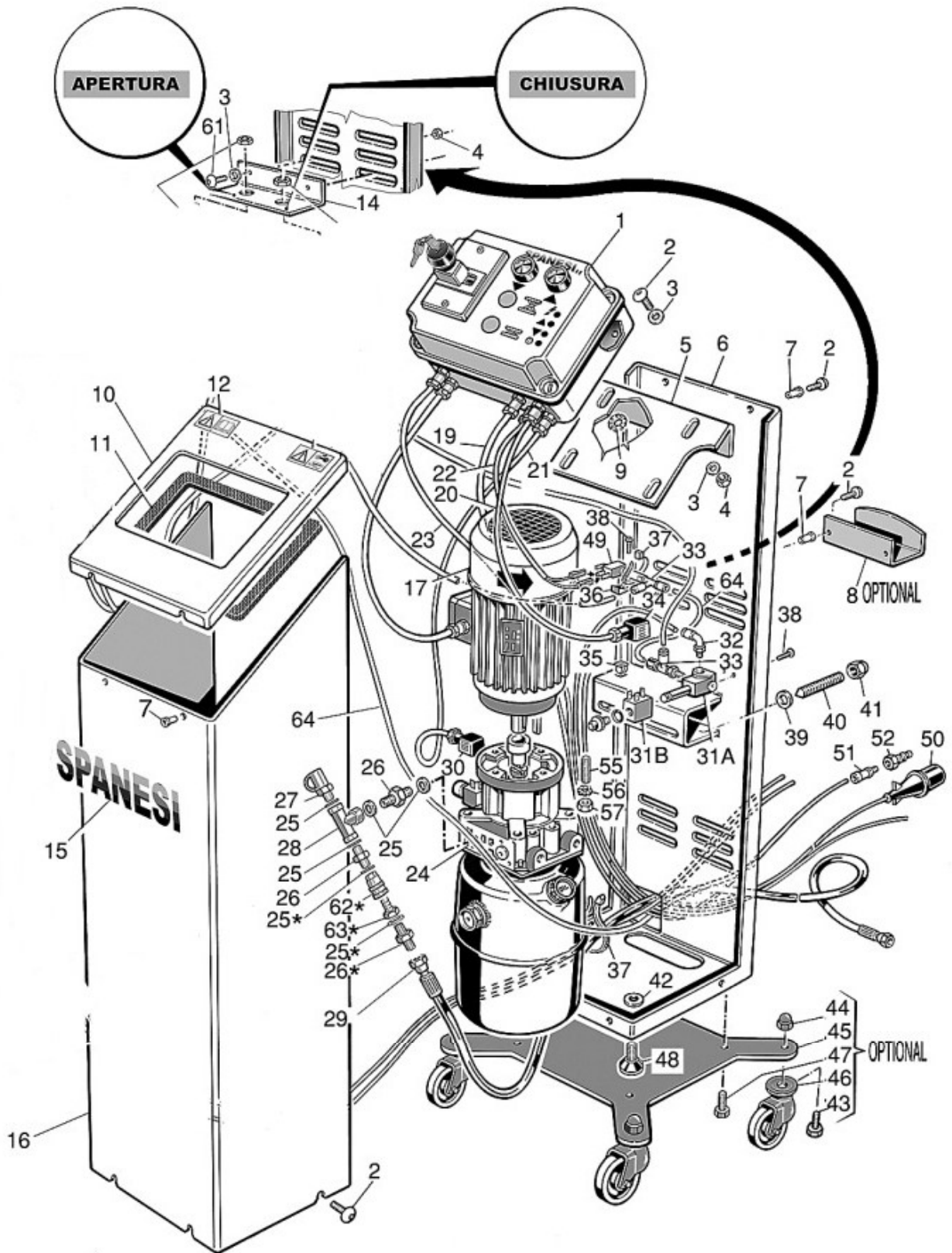

POS.	Q.TY	CODE	DESCRIPTION
44#	4	10031060	DADO E M12 UNI 5721 6.8 CIECO Zn BIANCO
45#	14	70104304	BASE CENTRALINA SOLLEVATORI VERN. RAL1023
46#	4	10071030	RUOTA GIR. PGA 080/QR
47#	4	10030560	VITE TCEI M10x30 UNI 5931 Zn BIANCA
48	4	10038322	PIEDINO IN GOMMA D.50x10MA art. 10315
49	1	10037373	TRASDUTTORE A FAST. 900.18.1/11
50	1	10055255	SPINA ILME PE 1664 SV 3P + T 16A 380v
51	1	10063128	RACC.RAP.DIR. 1/4 TUBO 6-4 010614
52	1	10037351	INNESTO RAPIDO 15/A OMNI 1/4 F PER ANI/CEJN
55	4	10030727	VITE STEI M8x35 UNI5923 PIANA NERA
56	1	10032010	RONDELLA GROWER D.8 DIN 127B
57	4	10031019	DADO E M8 UNI 5588 Zn BIANCO
58	2	10037404	RACC. 90 D.4 1/8 GIR.RAPIDO
61	2	10030405	VITE TBEI M6x12 Zn BIANCA
62*	1	10060021	INNESTO RAPIDO IR 06 PF F 1/4
63*	1	10060020	INNESTO RAPIDO IR 06 PM M 1/4

(#) OPTIONAL

POS.	Q.TY	CODE	DESCRIPTION
1	1	70105435	RIVESTIMENTO CENTRALINA SOLL.PONY-BP
2	1	10041001	ADESIVO SPANESI GRANDE 258x47mm
3	1	10041070	ADESIVO "COMANDI SALITA"
4	1	10041029	ADESIVO "VEDI MANUTENZIONE"
5	1	10041028	ADESIVO "VEDI ISTRUZIONI"
6	1	70105436	COPERCHIO CENTRALINA SOLL. PONY-BP
7	1	10055034	SELETTORE 1-0-2 L/LUNGA +2 VALV 3/2 POST
8	1	10055037	SELETTORE 0-1 L/LUNGA +1 VALV 3/2 POST
9	1	10055033	SELETTORE 1-0-2 L/LUNGA +2 VALV 3/2 POST
10	2	10037403	RACC. "Y" D.4 D.4 D.6
11	1	70105434	SCHIENALE CENTRALINA SOLL. PONY-BP
12	6	10037404	RACC. 90° D.4 1/8 GIR.RAPIDO
13	2	10037226	REGOLATORE DI FLUSSO 1/8 D.3
14	1	10037295	POMPA 240 BAR
15	-	10053250	LASTRA BUGNATA
16	4	10038322	PIEDINO IN GOMMA D.50x10MA art. 10315
17	1	10037362	TUBAZ. R7 TA 1/4 L=5000 FD+FD
18	8	10031314	INSERTO TC M6-030 L= 12.5 RK01
19	8	10030400	VITE TBEI M6x16 Zn BIANCA
20	3	10080097	RACC. SUPER RAP DIR. TUBO D6-D4
21	1	10037405	ELEMENTO OR 1/8"
22	1	10037348	RACC. "T" D.6 1/8 GIR. RAPIDO
23	1	10060108	ATTACCO A "T" 1/4" F/F/F
24	1	10060136	NIPPLE 1/4 -1/4 M
25	1	10060061	RACCORDO 1/4 8x10
26	2	10037349	RACCORDO "T" D.6 RAPIDO
27	1	10037406	ELEMENTO OR D.4
28	1	70105437	SUPPORTO DISPOSITIVO PNEUMATICO
29	-	10061251	TUBO RILSAN D.4x6 AZZURRO
30	4	10031316	INSERTO TC M10-035 L=23 RK01 DE13
31	-	10061248	TUBO RILSAN D.2,7x4 BIANCO
32	1	10063128	RACCORDO RAP.DIR. TUBO 6-4
33	-	10061249	TUBO RILSAN D.2.7x4 BIANCO
34	-	10061252	TUBO RILSAN D.4x6 BIANCO
35	2	10037355	RACCORDO 90° D.6 1/8 GIR.RAPIDO
36	-	10061262	TUBO FLESS. ELESTOLAN. 7.5x10 C98 SH CELESTE



Spanesi S.p.A.

Via Praarie 56/II, Loc. Cavino  
35010 S.S. delle Pertiche (PD)

Servizio Assistenza Tecnica

T. (+39) 049 9333211

F. (+39) 049 5741295

[spanesi@spanesi.it](mailto:spanesi@spanesi.it)

[www.spanesi.com](http://www.spanesi.com)

SPANESI 360 CONCEPT